

Comparison of Different Rules Based Fuzzy Logic Controller for PMSM Drives

¹Deepa Bajpai, ²Abhijit Mandal

¹Disha Institute of Management and Technology, Raipur, India,

²Asst. Prof. EEE department Disha Institute of Management & Technology Raipur, India

Abstract: An electric drive performance is paramount for crucial motion application and greatly influenced by capabilities of controller. For high performance application, vector control technique is normally applied with the permanent magnet induction motor (PMSM) drive. Instead of conventional PID controller fuzzy logic controller (FLC) has been widely used for such application. However, the real time computational burden is directly influencing by size of rule-based of FLC, which subsequently restricts its application with the processors of limited speed and memory. The performance of drive and the number of rule base are inversely with each other. It is evident that don't equally participate all the rules in the response and can be reduced for simplicity which utilizing less computational resources. In this paper, presented for three different rule based namely 49, 25 and 9 rules for the performance of vector controlled PMSM drives. The performance of the drive has been investigated for speed control at load and at no load. With larger FLC rule base the performance of drive system is found superior as compared to the lesser rules at the cost of large computational resources and speed.

Keywords: PMSM drives, vector control, Fuzzy logic controller.

I. Introduction

Induction motor speed control despite of various advantages due to complex mathematical model, nonlinearities such as core saturation, unpredictable load disturbances and coupling of variables. For speed control application where high performance needed such as aircraft, surgical and robotics application sometimes these factors make the precious speed control impossible with the conventional controllers making them inefficient and inaccurate.

In recent years, for its superior performance in speed control application FLC is distinguished and captured the attention of researchers. FLC's have the advantage to handle the system nonlinearities, and its control performance is not much affected by system parameter variation.

Numerous researchers have proposed the different aspects of designing of FLC rule base. Mostly compared the designed FLC with PI controller in terms of speed control performance. In most of the study's authors have used performance of the fix and distinctive parameters for FLC designing. The first choice for the simpler FLC designing is standard rule base 49 rules with triangular membership functions. In the decision making all the rules from the rule base doesn't contribute significantly and can be eliminated leading to a less computational burden and reduce memory requirement.

The objective of this paper is providing a detailed comparative analysis of FLC with different rule base size, employed in

PMSM drives. For different loading condition performance evaluation was carried out through simulation result. The system is dynamically simulated using Simulink /MATLAB Software

II. Vector Control Of Pmsm Drives

A. Pmsm Drives

Permanent magnet induction motor is introduced in order to overcome the problem associated with synchronous motor. In PMSM a permanent magnet is used in place of excitation coil. The stator current of an IM contain magnetizing as well as torque producing component. The use of the permanent magnet in rotor of the PMSM makes it unnecessary to supply magnetizing current through the stator for constant air gap flux, the stator current need only to torque producing. At the higher power factor, the PMSM will be more efficient than the IM.

B. Vector Control Technique

For ac IM the most popular technique is vector control. In the special reference frames, the expression for the smooth-air-gap machine is similar to the expression for the torque of the separately excited DC machine. In case of IM, the reference frame (d-q) attached to the rotor flux space vector, the control is usually performed in this reference frame. That's why the implementation of vector control requires information on the module and

the space angle of the rotor flux space vector. By utilizing transformation to the d-q coordinate system, the stator current of the IM are separated into flux and torque producing component, whose direct axis is aligned with the rotor flux space vector. That means the rotor flux q-axis component of space vector is always zero.

$$\Psi_{rq} = 0 \quad \text{and} \quad \frac{d}{dt}\psi_{rq} = 0 \quad (1)$$

The main objective of the vector control of IM is that, by using a d-q rotating reference frame synchronously with the rotor flux space vector is to independently control the flux and the torque. In ideally field-oriented control, the rotor flux linkage axis is forced to align with the d-axis. Applying the result of both, equation namely field-oriented control, the torque equation becomes analogous to the DC machine and can be described as follows,

$$T_e = \frac{3}{2} \frac{pL_m}{L_r} \psi_r i_{qs} \quad (2)$$

III. System Description And Control

The Fig.1 shows the schematic diagram of FLC based IM drive system under analysis. The basic configuration of the drive consists of an IM fed by a current-controlled voltage- source inverter.

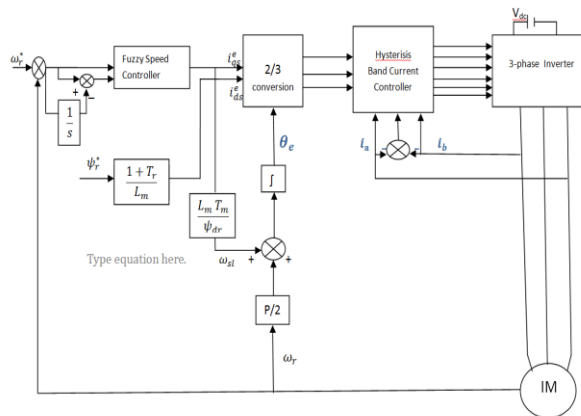

Fig.1 Schematic diagram of indirect vector control PMSM drive

In this work for high performance the indirect vector control technique is incorporated. The actual rotor speed ω_r measured and compared with the ω_r^* . The reference torque T_r^* is calculated as the output, when the resulting error generated from the comparison of the two speeds processed in the controller. A limiter is used to limit the reference torque T_r^* in order to generate the q-axis reference current i_{qs}^{e*} . The d-axis reference current set to zero. Both d-axis and q-axis stator current generate three phase reference current (i_a^* , i_b^* and i_c^*) through Park's Transformation which are compared with sensed winding current (i_a , i_b and i_c) of the IM. The control signals generated after the comparing the sensed current and reference current will fire the power semiconductor devices of the three-phase voltage source inverter (VSI) to produce the actual voltage to be fed to the induction motor. In synchronously rotating reference frame the mathematical model for a three-phase y-connected squirrel-cage induction motor under steady state condition and load is given as [10-11].

$$\begin{bmatrix} I_{qs}^e \\ I_{ds}^e \\ I_{qr}^e \\ I_{dr}^e \end{bmatrix} = \begin{bmatrix} R_s & \omega_s L_s & 0 & \omega_s L_m \\ -\omega_s L_s & R_s & -\omega_s L_m & 0 \\ 0 & \omega_{sl} L_m & R_r & \omega_{sl} L_r \\ -\omega_{sl} L_m & 0 & -\omega_{sl} L_r & R_r \end{bmatrix} \begin{bmatrix} v_{qs}^e \\ v_{ds}^e \\ 0 \\ 0 \end{bmatrix} \quad (3)$$

$$T_e = \frac{3}{2} \frac{p}{2} L_m (i_{qs}^e i_{dr}^e - i_{ds}^e i_{qr}^e) \quad (4)$$

$$T_e - T_L = J \frac{d\omega_r}{dt} + B\omega_r \quad (5)$$

$$\frac{d\theta_r}{dt} = \omega_r \quad (6)$$

Where i_{ds}^e, i_{qs}^e are d,q-axis stator current respectively, v_{ds}^e, v_{qs}^e are d,q-axis stator voltages respectively, i_{dr}^e, i_{qr}^e are d,q-axis rotor current respectively R_s, R_r are stator and rotor resistance per phase respectively, L_s, L_r are the self inductances of the stator and rotor respectively, L_m is the mutual inductance, ω_e is the speed of the rotating magnetic field, ω_r is the rotor speed, p is the number of poles, T_e is the developed electromagnetic torque, T_L is the load torque, J is the inertia, B is the rotor damping coefficient and θ_r is the rotor position. The key feature of the vector control is to keep the magnetizing current at a constant rated value by setting $i_{dr}^e = 0$. Thus, by adjusting only the torque-producing current component the torque demand can be controlled. With this assumption, the mathematical formulation can be rewritten as

$$\omega_{sl} = \frac{R_r i_{qs}^e}{L_r i_{ds}^e} \tag{7}$$

$$i_{qs}^e = \frac{L_m}{L_r} i_{qr}^e \tag{8}$$

$$T_e = \frac{3 P L_m}{2 L_r} \psi_{dr}^e i_{qs}^e \tag{9}$$

Where ω_{sl} is the slip speed ψ_{dr}^e is the d-axis rotor flux linkage. The indirect vector controlled drive system with FLC assisted speed controller model is represented from equation (1) to equation (7).

IV. FLC Designing

Fig.2 show the general block diagram of FLC. The main objective of the designed FLC is to maintain the performance obtained by ‘standard design’ while reducing the complexity of fuzzy rule base design. FLC has mainly four internal component from which input has to be processed to come out as output.

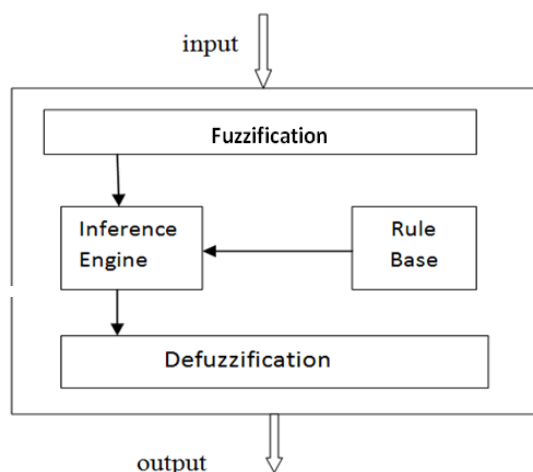

Fig.2 Block diagram of FLC

These component are –

Fuzzification- is the conversion of crisp numerical values into fuzzy linguistic quantifiers. Fuzzification is performed using membership functions. Each membership function evaluates how well the linguistic variable may be described by a particular fuzzy qualifier.

Inference Engine- The inference engine uses the fuzzy vectors to evaluate the fuzzy rules and producing an output for each rule. Mamdani type fuzzy inference engine is used for this particular work.

Defuzzification- in this process the combined output fuzzy set produced from the inference engine into a crisp output value of real-world meaning. Center of gravity defuzzification technique is used in this particular work.

A. Scaling Factor Calculation

For FLC the role of scaling factor is similar to gain coefficient in conventional controller, and it affects the oscillation, damping and stability of the system. Three scaling factors G_{se}, G_{cse} and G_{cu} for fuzzification as well as for obtaining the actual output of the command current are calculated using known motor data. A

common universe with values between [-1, 1], into it all the linguistic variables of the fuzzy controller system (speed error, speed error variation) were scaled.

The motor run 52.3 rad/s at rated speed and an assumption is made that this value is maximum speed of operation of the motor. Thus, maximum speed error is 52.3 for start-up from standstill and scaling factor for the speed error is obtained as [13]:

$$G_{se} = 1/52.3 = 0.01912 \tag{10}$$

For change in speed error, scaling factor is calculated on the basis of maximum torque and rated inertia that the motor is allowed to develop, taking sampling time 20 μs.

$$T_{e,max} = Jn/p(\Delta\omega/T_s) \rightarrow \Delta\omega = 0.0487 \text{ rad/sec}$$

$$G_{cse} = 1/cse = 1/(e(T_s) - e(0)) = 1/\Delta\omega = 20.5 \tag{11}$$

Output scaling factor is set to $G_{CU} = 2$.

B. Rule Base Designing

In this paper, with different rule base size the performance of FLC in order to compare with size of 9, 25 and 49 rules are designed for speed control of PMSM drives. A matrix basically used rule base for determining the controller output from their input(s) as it hold the input/ output relationships.

The rules used in the rule base of 9, 25 and 49 rules with the different FLC's are given in table shown in Tab. I, II and III respectively. For input and output variables the linguistic terms used are described as: "Z" is "Zero"; "N" is "Negative"; and "P" is "Positive", NL is Negative Large, NM is Negative Medium, NS is Negative Small, PL is Positive Large, PM is Positive Medium and PS is Positive Small The rules are in general format of "if antecedent1 and antecedent2 then consequent".

Table: I: Rule Base Array For FLC (9)

SE/CSE	N	Z	P
N	N	N	P
Z	N	Z	P
P	Z	P	P

Table: II: Rule Base Table For FLC (25)

SC/CSE	NL	NS	Z	PS	PL
NL	NL	NL	NL	NS	Z
NS	NL	NL	NS	Z	PS
Z	NL	NS	Z	PS	PL
PS	NS	Z	PS	PL	PL
PL	Z	PS	PL	PL	PL

Table: III: Rule Base Arrey For FLC(49)

SE/CSS	NL	NM	NS	Z	PS	PM	PL
NL	NL	NL	NL	NM	NM	NS	Z
NM	NL	NL	NM	NM	NS	Z	PS
NS	NL	NM	NM	NS	Z	PS	PM
Z	NM	NM	NS	Z	PS	PM	PM
PS	NM	NS	Z	PS	PM	PM	PL
PL	NS	Z	PS	PM	PM	PL	PL
PM	Z	PS	PM	PM	PL	PL	PL

C. Membership Function

In order to have unbiased comparison between the FLC's triangular membership function are used for designing the rule based in the work. For particular FLC the common inputs and output function are used as shown in Fig.3(a),Fig.(b) and Fig.(c) for 49,25 and 9 rule base respectively. All the membership functions are symmetrically spaced over the universe of discourse.

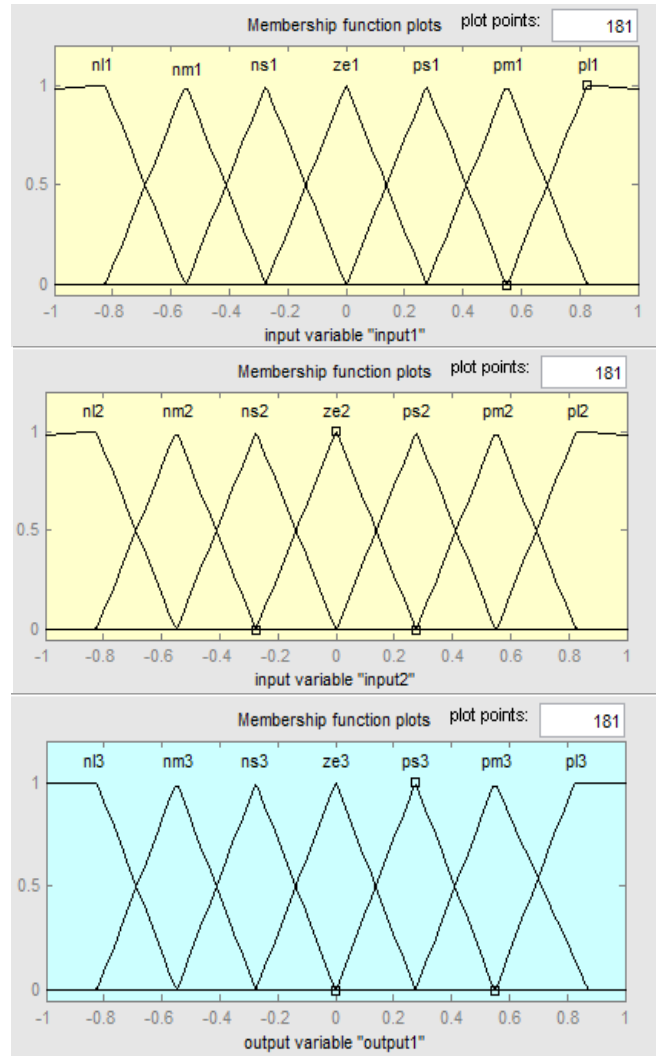
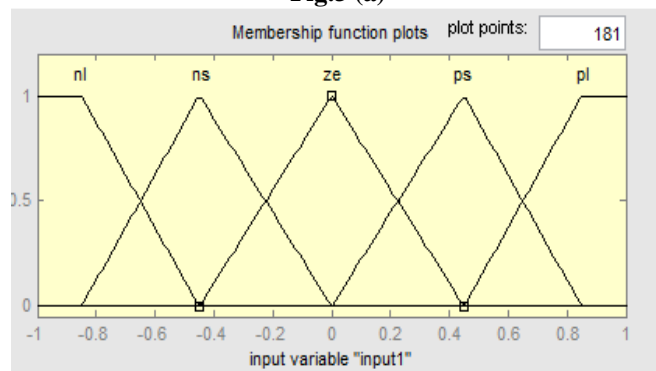

Fig.3 (a)



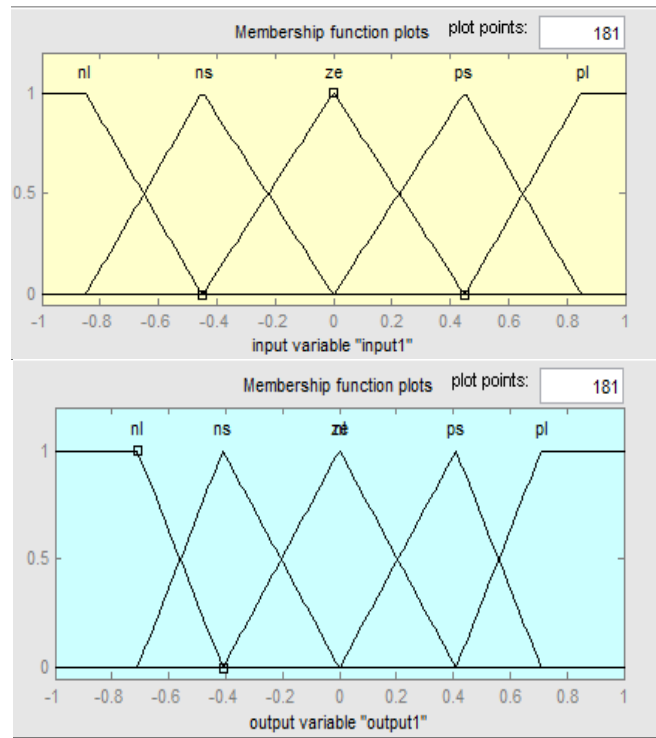

Fig.3 (b)

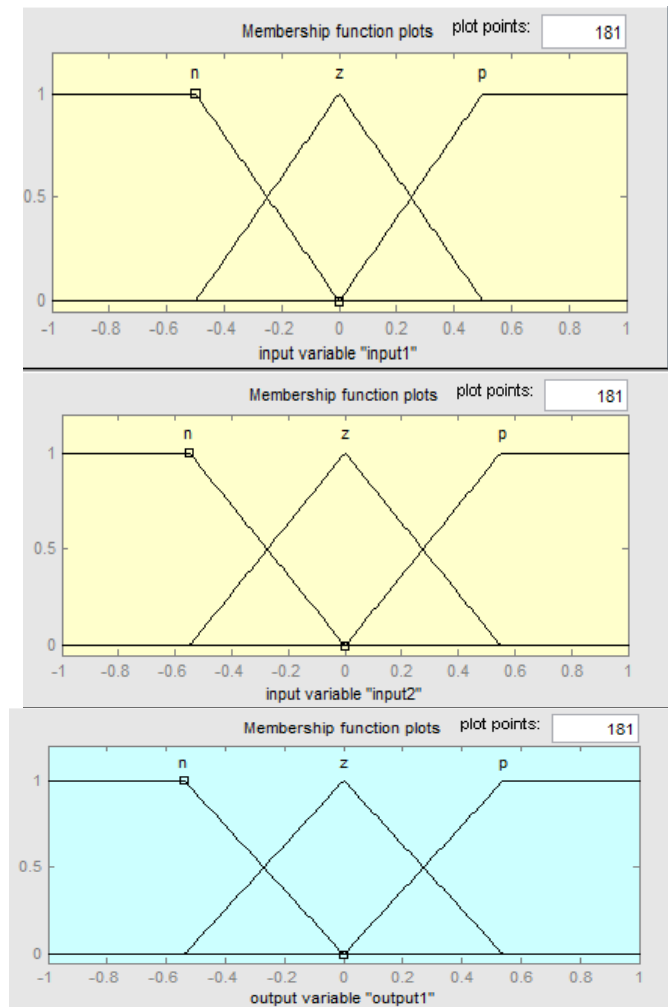

Fig.3 (c)

V. Result & Discussion

The performance evaluation of the FLC based PMSM drives shown in Fig. 4 the results of 9, 25 and 49 rules. It is evident from this figures that undershoot in the responses leads to increase in settling time when changing from 49, 25 and 9 rules base FLC system respectively.

Under consideration of discussed PMSM drives of the three FLC, the load rejection capability is shown in Fig.5 at rated speed 52.3 rad/sec. At time t=1 sec the step rated load is applied suddenly when the drive running at no load steadily. It is shown in the figures that the load rejection capability is improved in terms of steady state error and settling time when moving from lower rule base to higher rule base.

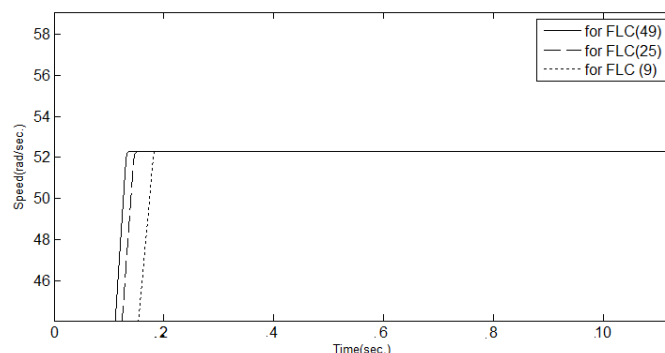

Fig.4. Speed tracking capability of drive for three FLC rule base at speed of 52.3 rad/sec

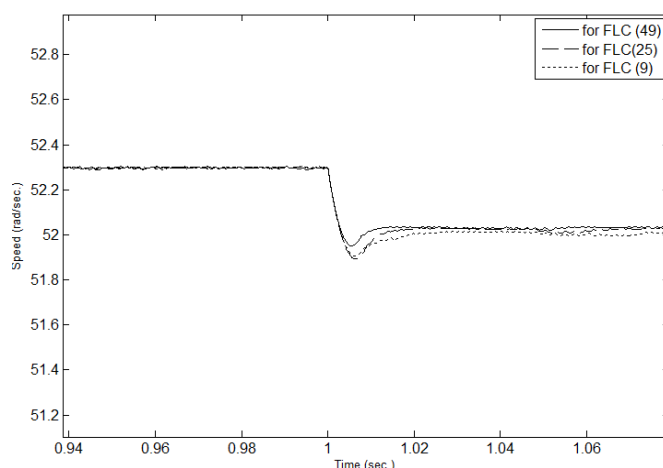

Fig.5. Load rejection capability of drive for three FLC rule based at speed of 52.3 rad/sec.

VI. Conclusion

In this paper compare the performance of indirect vector controlled technique with proposed FLC for speed control loop for three different FLC rule bases namely 49, 25 and 9rules. The dynamic model of drive system has been developed in Simulink/MATLAB. The drive performance has been evaluated for reference speed tracking, disturbance rejection control capability. In Fig.4 and 5 x-axis is show's time (10^{-1} sec.) and y-axis speed (rad/sec.), yellow line show the response of FLC with 49 rules base, pink line used for FLC with 25 rules based and blue line shows the response of FLC with 9 rules based. It has been observed that the performance of drive system using larger FLC rule base has been found excellent as far as performance indices have been concerned in comparison with the performance with lesser rules but at the cost of large computational resources and speed.

References

- [1]. B. K. Bose, Modern Power Electronics and AC Drives, Eaglewood Cliffs, New Jersey: Prentice hall, 1986.
- [2]. M. N. Uddin, T. S. Radwan, and M. A. Rahman, "Performances of Fuzzy-Logic-Based Indirect Vector Control for Induction Motor Drive," IEEE Trans. Industry Applications, vol. 38, no. 5, pp. 1219-1225, Sep./Oct. 2002.
- [3]. T. S. Radwan, M. N. Uddin, and M. A. Rahman, "A new and simple Structure of fuzzy logic based Indirect Field Oriented Control of Induction Motor Drive," in Proc.35th Annual IEEE Power Electronics Specialists Conference, Germany, 2004, pp. 3290-3294.
- [4]. Z. Ibrahim and E. Levi, "A Comparative Analysis of Fuzzy Logic and PI Speed Control in High-Performance AC Drives Using Experimental Approach," IEEE Trans. on Industry applications, vol. 38, no. 5, pp. 1210-1218, Sep./Oct. 2002.
- [5]. C. Shanmei, W. Shuyun, and D. Zhengeheng, "A Fuzzy Speed Controller of Induction Motors," in Proc. International Conference on Intelligent Mechatronics and Automation, China, 2004, pp. 747-750.
- [6]. B. Sahu, K. B. Mohanty, and S. Pati, "A Comparative Study on Fuzzy and PI Speed Controllers for Field-Oriented Induction Motor Drive," in Proc. International Conference on Industrial Electronics, Control and Robotics, India, 2010, pp. 191-196.

- [7]. B. Kumar, Y. K. Chauhan, and V. Shrivastava, "Performance Evaluation of Reduced Rule Base Fuzzy Logic Controller for Indirect Vector Controlled Induction Motor Drive," in Proc. 4th International Conference on Computer Simulation and Modeling, Hong Kong, 2012, pp. 81-86.
- [8]. M. Masiala, B. Vafakhah, A. Knight, and J. Salmon, "Performances of PI and Fuzzy-Logic Speed Control of Field-Oriented Induction Machine Drives," in Proc. Canadian Conference on Electrical and Computer Engineering, 2007, Canada, pp. 397-400.
- [9]. C. B. Butt, M. A. Hoque, and M. A. Rahman, "Simplified Fuzzy-Logic-Based MTPA Speed Control of IPMSM Drive," IEEE Trans. Industry Applications, vol. 40, no. 6, pp. 1529-1535 Nov./Dec. 2004.
- [10]. M. N. Marwali, "Implementation of Indirect Vector Control on an Integrated Digital Signal Processor - Based System," IEEE Trans. Energy Conversion, vol. 14, no. 2, pp. 139-146, June 1999.
- [11]. N. Mariun, S. B. M. Noor, J. Jasni, and O. S. Bennanes, "A fuzzy logic based controller for an indirect vector controlled three phase induction motor," in Proc. IEEE Region 10 conference TENCON, Bangkok 2004, pp. 1-4.
- [12]. C. Zang, "Vector controlled PMSM drive based on fuzzy speed controller," in Proc. International Conference on Industrial mechatronics and Automation, China, 2010, pp. 199-202.
- [13]. B. N. Kar, K. B. Mohanty, and M. Singh, "Indirect vector control of induction motor using fuzzy logic controller," in Proc. International conference on Environment and Electrical Engineering, Rome, 2011, pp. 1-4.