

New Topology of Cascaded H-Bridge Multilevel Inverter

Abhishek Chauhan¹, Jyotsana Kothiyal², Gaurav Singh Negi³

¹(M.Tech, Uttarakhand Technical University, India)

²(Assistant Professor, Uttaranchal University, India)

³(M.Tech Scholar, Uttarakhand Technical University, India)

Abstract: This paper mainly deals with three different topologies of cascaded H-Bridge multilevel inverter. The Existing Topology is a general type of multilevel inverter and has two DC sources for each phase. In Proposed Topology -I the number of DC sources has been reduced to one for all the three phases and the usage of transformers comes into picture. Proposed Topology-II has also only one DC source for all the three phases and the number of switches has been reduced than compare to all other proposed topologies of Cascaded H-bridge multilevel inverter. MATLAB simulations has been carried out for all three Topologies and compared with each other.

Keywords: Level Inverter (MLI), Multilevel Inverter with Single DC Source, transformers, THD

I. Introduction

Multilevel Converters are a very interesting solution for medium and high voltage applications. Because of its characteristic of synthesize a sinusoidal voltage on several DC levels. The better topology for power quality and transmission systems applications is the cascade multilevel inverters [1, 2]. However, this topology presents a problem that consists in the use of several DC sources. In the last years multilevel inverters have had a great relevance in transmission and distribution systems, due to its general structure which synthesizes a sinusoidal voltage in many voltages levels. Multilevel inverter generate an output signal with low THD because of this the size of the output filter reduces whose cut-off frequency depends on the modulation technique and the switching frequency used. In addition it can be possible to use PWM modulation [3, 4] over each step staircase voltage, generating a high PWM frequency output. The Existing Topology of cascaded H-Bridge multilevel inverter is general type of Multi Level Inverter (MLI) and it has two DC sources for each phase and number of semi conductor switches for each phase is eight [5, 6]. Fig.1 shows the general type cascaded H-Bridge multilevel inverter. Proposed Topology-I employs one single dc input power source and isolated three-phase low-frequency transformers [7, 8]. The number of DC sources has been reduced to one for all the three phases. It is possible to increase the power density of the circuit. In the Proposed Topology-II the total number of switches has been reduced to six when compared to Existing Topology and the use of capacitors in this circuit is more in this topology and more over the number of DC sources has been reduced to one for all the three phases [9, 10]. It is possible to increase the power density of the circuit because of removing bulky inductor. By the Proposed Topology-I circuit configuration, the number of transformers can be reduced and compared with the traditional three-phase MLI using single-phase transformers [11, 12]. Therefore it is more economical and efficient inverter can be designed. Basically, the switching frequency of each H-bridge inverter is uniform with output fundamental frequency. To verify the performance of the proposed cascaded multilevel inverter, simulations were carried out.

II. Cascaded H-Bridge Multilevel Inverter (Existing Topology)

The N-level cascaded H-bridge, multilevel inverter comprises (N-1)/2 series connected single phase H-bridges per phase, for which each H-bridge has its own isolated dc source. Three output voltages are possible, $\pm V_s$, and zero, giving a total number of states of $3(N-1)/2$, where N is odd. Figure 1 shows one phase of a 5-level cascaded H-bridge inverter. Its main limitation lies in its need for isolated power sources for each level and for each phase, although for VA compensation, capacitors replace the dc supplies, and the necessary capacitor energy is only to replace losses due to inverter losses. Its modular structure of identical H-bridges is a positive feature.

- The number of levels in the line-to-line voltage waveform will be $k = 2N - 1$.
- While the number of levels in the line to load neutral of a star (wye) load will be $p = 2k - 1$.
- The number of capacitors or isolated supplies required per phase is $N_{cap} = (N - 1)/2$.
- The number of possible switch states is $n_{states} = N_{phases}$.
- The number of switches in each leg is $S_n = 2(N - 1)$.

Due to the advantages, the cascaded inverter bridge has been widely applied to such applications as HVDC, SVC, stabilizer, high power motor drive and so on. This topology of inverter is suitable for high voltage and high power inversion because to its ability to synthesize waveforms with better harmonic spectrum and low switching frequency.

Advantages:

1. The number of possible output voltage levels is more than twice the number of dc sources ($m = 2s + 1$).
2. The series of H-bridges makes for modularized layout and packaging. This will enable the manufacturing process to be done more quickly and cheaply.

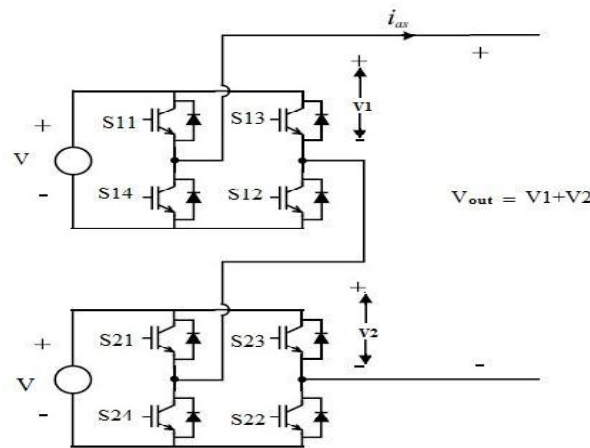

Fig.1 Single Phase Cascaded H-Bridge 5 level MLI

Disadvantages: Separate dc sources are required for each of the H-bridges. This will limit its application to products that already have multiple SDCSs readily available

III. Cascaded H-Bridge Multilevel Inverter Employing Transformer And Single Dc Input Power Source (Proposed Topology-I)

This technique consists of an isolated cascaded multilevel inverter employing low-frequency three-phase transformers and a single dc input power source. This circuit configuration reduces a number of transformers compared with traditional three-phase multilevel inverters using single-phase transformers. It controls switching phase angles to obtain an optimal switching pattern identified with the fundamental frequency of the output voltage. Owing to this control strategy, harmonic components of the output voltage and switching losses can be diminished considerably.

H-bridge modules are connected to the same dc input source in parallel, and each secondary of the transformer is connected in series. In this configuration, the output voltage becomes the sum of the terminal voltages of each H-bridge module. The amplitude of the output voltage is determined by the input voltage and turn ratio of the transformer. Usually, a traditional cascaded H-bridge converter employs a multi pulse isolation transformer to obtain the input dc source. When the traditional cascaded H-bridge converter needs to isolate from the ac output, it requires a three-phase transformer between the inverter and the ac outputs. On the other hand, the proposed inverter has an advantage of galvanic isolation between the source and the output voltages, which comes from being combined with transformers. However, when the circuit, shown in Fig. 3, needs to modify its configuration for use in three-phase applications, there is a drawback, which is the requirement of more transformers, considering that the same number of transformers needs to be used in each phase.

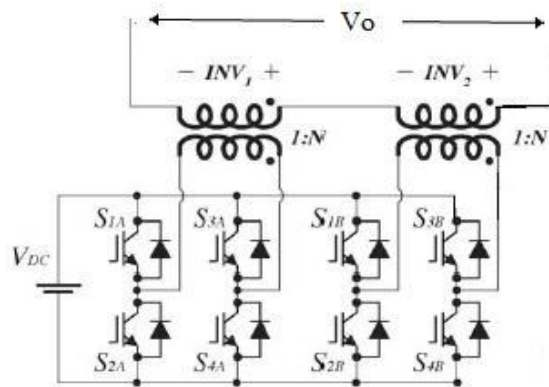

Fig.3 Circuit Diagram of Proposed Topology-I

IV. Hybrid Multilevel Inverter With Single Dc Source (Proposed Topology-Ii)

Hybrid multilevel inverter includes a standard 3-leg inverter (one leg for reach phase) and H-bridge in series with each inverter leg. The inverter can be used in hybrid electric vehicles and electric vehicles. Also, it is possible to increase the power density because the inverter removes the bulky inductor of the present DC-DC boost converter. Figure Below shows the proposed technique.

Principal of Operation:

A simplified single -phase topology is shown in Fig. 4 the bottom is one leg of a standard 3-leg inverter with a dc power source. The top is an H-bridge in series with each standard inverter leg. The H-bridge can use a separate dc power source or a capacitor as the dc power source. The output voltage V_1 of this leg (with respect to the ground) is either $+V_{dc}/2$ (S_5 closed) or $-V_{dc}/2$ (S_6 closed). This leg is connected in series with a full H-bridge which in turn is supplied by a capacitor voltage. If the capacitor is kept charged to $V_{dc}/2$, then the output voltage of the H-bridge can take on the values $+V_{dc}/2$

(S_1, S_4 closed), 0 (S_1, S_2 closed or S_3, S_4 closed), or $-V_{dc}/2$ (S_2, S_3 closed). When the output voltage $V = V_1 + V_2$ is required to be zero, one can either set $V_1 = +V_{dc}/2$ and $V_2 = -V_{dc}/2$ or $V_1 = -V_{dc}/2$ and $V_2 = +V_{dc}/2$. It is this flexibility in choosing how to make that output voltage zero that is exploited to regulate the capacitor voltage. Here only a dc power source is used in the inverter, that is, the H-bridge uses a capacitor as the dc power source.

If S_1, S_4 are closed (so that $V_2 = +V_{dc}/2$) along with S_6 closed (so that $V_1 = -V_{dc}/2$), then the capacitor is discharging and $V = V_1 + V_2 = 0$. On the other hand, if S_2, S_3 are closed (so that $V_2 = -V_{dc}/2$) and S_5 is also closed (so that $V_1 = +V_{dc}/2$), then the capacitor is charging and $V = V_1 + V_2 = 0$. The method consists of monitoring the capacitor voltage so that during periods of zero voltage output, either the switches $S_1, S_4,$ and S_6 are closed or the switches S_2, S_3, S_5 are closed depending on whether it is necessary to charge or discharge the capacitor.

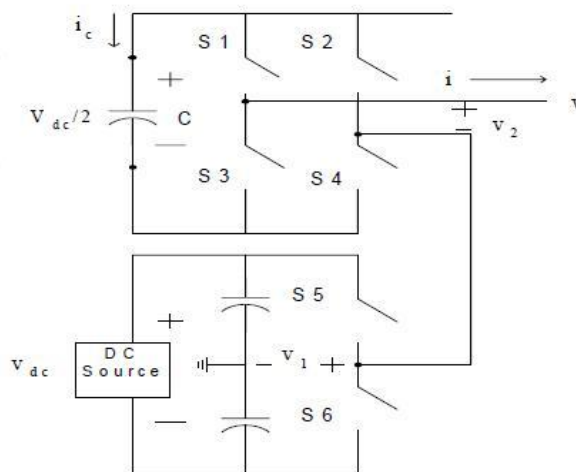

Fig. 4 Single Phase Proposed Topology-I

V. Simulation Studies

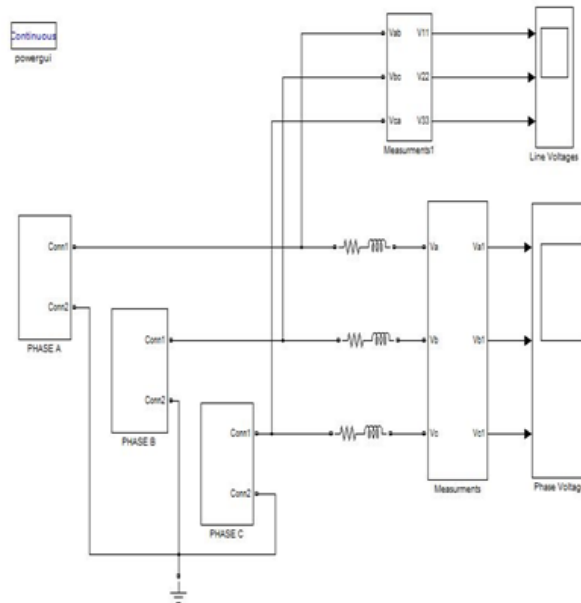

Fig.5 Simulation of Cascaded H-Bridge MLI(Existing Topology)

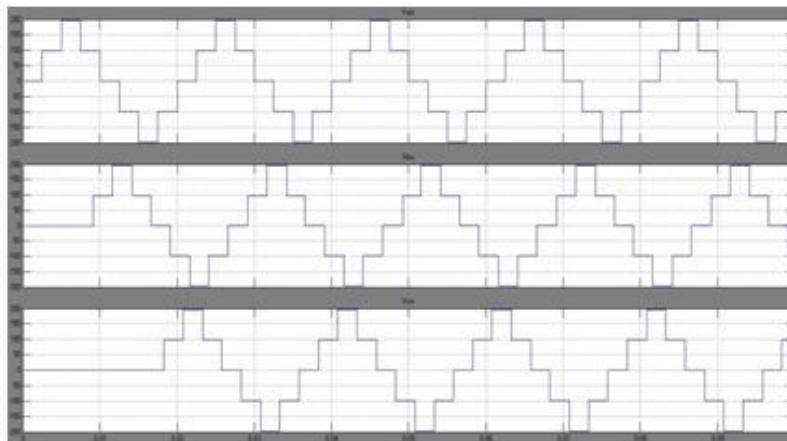

Fig.6 Output Phase Voltages of Existing Topology

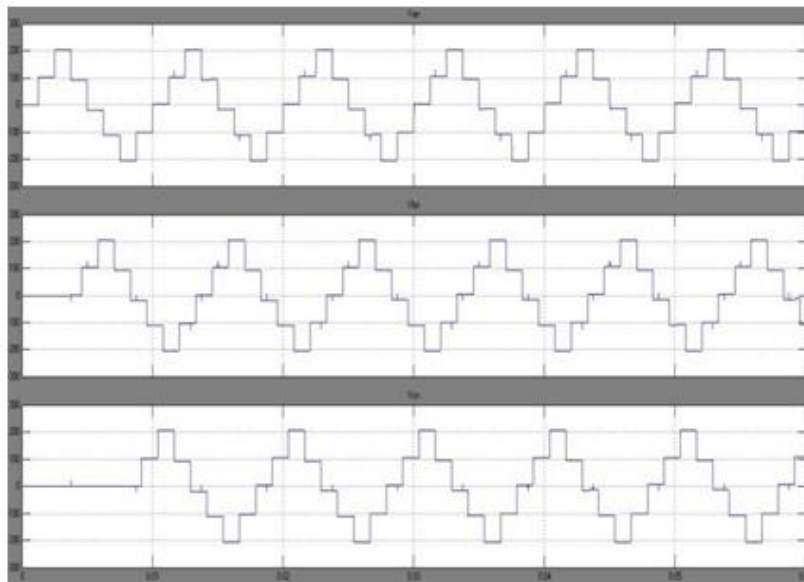

Fig.11 Output Phase Voltages of Proposed Topology-I

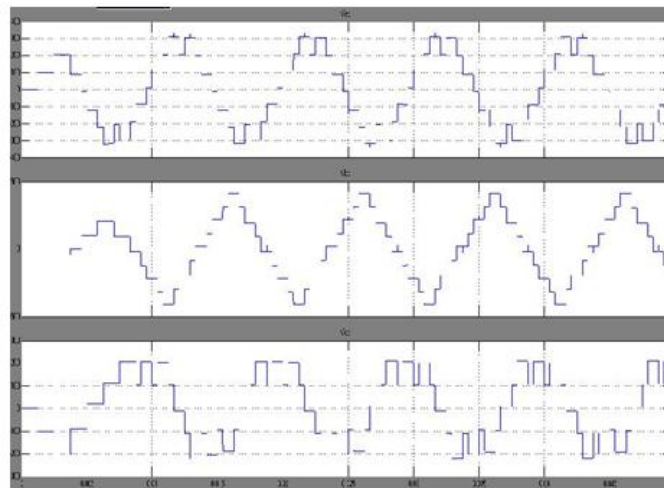

Fig.13 Output Line Voltages of Proposed Topology-I

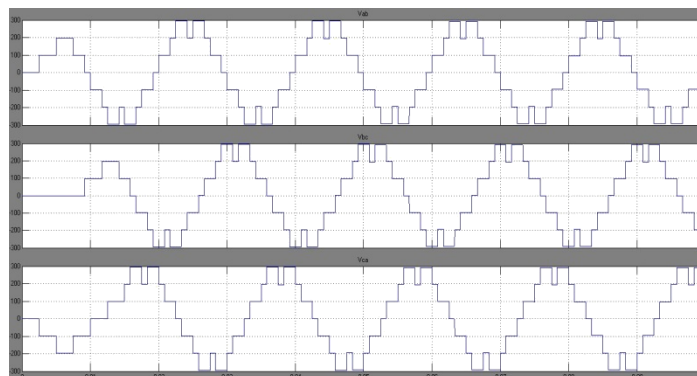

Fig.18 Output Line Voltages of Proposed Topology-II

MLI Type	Phase - Neutral		Phase - Phase	
	Voltage (V)	THD	Voltage (V)	THD
Existing Topology	163	28.13	280.8	19.97
Topology 1	170.5	29.05	287.1	21.02
Topology 2	162.1	29.28	270.9	21.28

Table.1 Comparison of All Topologies

Topologies	No.of DC Sources(V_{dc})	No.of Switches	No.of Capacitors	No.of Transformers
Existing	6	24	0	0
Proposed-I	1	24	0	6
Proposed-II	1	18	4	0

Table.2 Requirement of Equipment's for 5 Level MLI

VI. Conclusion

In this paper three different topologies of cascaded Multilevel Inverter has been simulated .Out of the above three topologies Existing Topology of cascaded H-Bridge Multilevel Inverter is best based on the FFT analysis observed from the Simulation of all the Above Topologies. H-bridge MLI With single DC source is best if we consider Cost, switching Losses.

References

- [1]. Fang ZhengPeng, Jih-Sheng Lai, and Rodriguez, J. "Multilevel inverters: a survey of topologies, controls, and applications", *Industrial Electronics, IEEE Transactions*, Vol. 49, issue:4, pp. 724-738, Aug 2002.
- [2]. S. Khomfoi, L. M. Tolbert, "Multilevel Power Converters," *Power Electronics Handbook*, 2nd Edition Elsevier, 2007, ISBN 978-0-12-088479-7,
- [3]. Chapter 17, pp. 451-482.
- [4]. Holmes, D.G, McGrath, B.P. "Multicarrier PWM strategies for multilevel inverters" *Industrial Electronics, IEEE Transactions*, Vol. 49, issue:4, pp.858-867, Aug 2002.
- [5]. Yan Deng, Hongyan Wang, Chao Zhang, Lei Hu and Xiangning He, "Multilevel PWM Methods Based On Control Degrees Of Freedom Combination And Its Theoretical Analysis", *IEEE IAS 2005 Conference record no.:0-7803-9208-6/05*, pp. 1692 – 1699, 2005.
- [6]. J. Rodríguez, B. Wu, S. Bernet, J. Pontt, and S. Kouro, "Multilevel voltage-source-converter topologies for industrial medium-voltage drives," *IEEE Trans. Ind. Electron.*, vol. 54, no. 6, pp. 2930–2945, Dec. 2007.
- [7]. Fang ZhengPeng, Jih-Sheng Lai, John W. McKeever, and James VanCoevering. "A multilevel voltage-source inverter with separate dc sources for static var generation" *IEEE Trans. Industry Applications*, vol.32, no.5, pp.1130-1138, Sept. 1996.
- [8]. "Optimized Hybrid Phase Disposition PWM Control Method for Multilevel Inverter" C.Govindaraju and Dr.K.Baskaran *International Journal of Recent Trends in Engineering*, Vol 1, No. 3, May 2009
- [9]. "A modular power electronic transformer based on a cascaded H-bridge multilevel converter" H. Iman -Einia, b, Sh. Farhangia, J.-L. Schanenb,*, M. Khakbazan-FardcH. Iman-Eini et al. / *Electric Power Systems Research* 79 (2009) 1625–1637.
- [10]. Samir Kouro, Student Member, IEEE, Pablo Lezana, Member, IEEE, Mauricio Angulo, and José Rodríguez, Senior Member, IEEE *IEEE Transactions on Power Electronics*, Vol. 23, No. 1, January 2008 "Multi carrier PWM With DC-Link Ripple Feed forward Compensation for Multilevel Inverters".
- [11]. PanagiotisPanagis, FotisStergiopoulos, PantelisMarabeas and Stefanos Manias "Comparison of State of the Art Multilevel Inverters". 978-1-4244-1668-4/08/2008 IEEE
- [12]. Alan Joseph, et al. "A 24-pulse rectifier cascaded multilevel inverter with minimum number of transformer windings," *IEEE Fourtieth IAS Annual Meeting*, vol.1, Oct. 2005, pp.115-120.
- [13]. D. A. Rendusara, E. Cengelci., P. N. Enjeti, V. R. Stefanovic, and J. W.Gray. "Analysis of common mode voltage neutral shift in medium voltage PWM adjustable speed drive (MV-ASD) systems" *IEEE Trans. Power Electronics*, vol.15, no.6, pp.1124-1133, Nov. 2000.
- [14]. Leon M.Tolbert, Fang ZhengPeng, Tim Cunnyngham and John N.Chiasson. "Charge balance control schemes for cascade multilevel converter in hybrid electric vehicles" *IEEE Trans. Industrial Electronics*, vol. 49, no.5, pp.1058-1064, Oct. 2002.
- [15]. A 5-Level Cascaded Hybrid Multilevel Inverter for Interfacing with Renewable Energy Resources" Surin Khomfoi, Chatrchai Aimsaard 978-1-4244-3388-9/09/2009 IEEE