

Non-Linear static analysis of RC frame structure

Santhosh.D¹, N.Jayaramappa²

¹ Assistant professor, Dept. of Civil Engg, Sri Krishna Institute of Technology (SKIT), Bangalore, Karnataka, India

² Assistant professor, Dept. of Civil Engg, University Visvesvaraya College Of Engineering (UVCE), Bangalore, Karnataka, India

Abstract: Pushover analysis is a non linear static analysis becoming a popular tool for seismic performance evaluation of existing and new structures and used to determine the force-displacement relationship for a structural element. To evaluate the performance of RC frame structure, a non linear static pushover analysis has been conducted by using ETABS 9.7.1. To achieve this objective, five RC frame structures with 5 story 1bay, 5 story 2bay, 5 story 3bay, 5 story 4bay, 5 story 5bay respectively were analyzed. And also compared the base force and displacement of RC frame structure with 5 story 1bay, 5 story 2bay, 5 story 3bay, 5 story 4bay, 5 story 5bay.

Keywords: ETABS 9.7.1, Hinge properties, Non linear static analysis, Pushover analysis, RC frame.

I. Introduction

The static pushover analysis is becoming a popular tool for seismic performance evaluation of existing and new structures. The expectation is that the pushover analysis will provide adequate information on seismic demands imposed by the design ground motion on the structural system and its components. Pushover analysis is provide 'capacity curve' of the structure, it is a plot of total base force vs. roof displacement. The pushover analysis of a structure is a analysis under permanent vertical loads and gradually increasing lateral loads. The equivalent static lateral loads approximately represent earthquake induced forces. A plot of the total base shear versus top displacement in a structure is obtained by this analysis that would indicate any premature failure or weakness and this analysis is a method to observe the successive damage state of the building.

1. FORCE DEFORMATION BEHAVIOR OF HINGES

- Point A corresponds to unloaded condition.
- Point B represents yielding of the element.
- The ordinate at C corresponds to nominal strength and abscissa at C corresponds to the deformation at which significant strength degradation begins.
- The drop from C to D represents the initial failure of the element and resistance to lateral loads beyond point C is usually unreliable.
- The residual resistance from D to E allows the frame elements to sustain gravity loads.

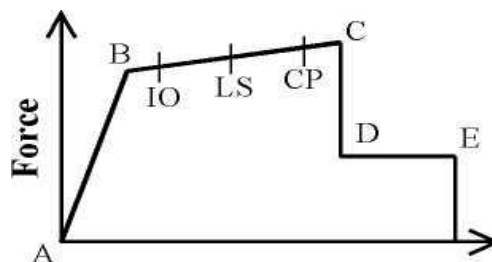

Fig A. Graph shows the curve Force Vs Deformation

- Beyond point E, the maximum deformation capacity, gravity load can no longer be sustained

2. PERFORMANCE LEVELS AND RANGES

The building performance level is a function of the post event conditions of the structural and non-structural components of the structure. The performance levels are as follows:

- Immediate Occupancy
- Life Safety

- Collapse Prevent

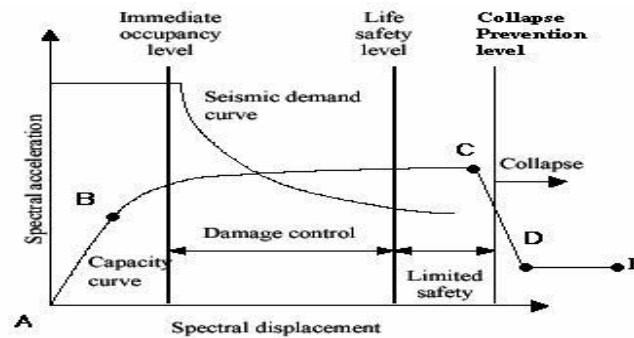

Fig B. Performance levels and ranges

2.1) Immediate Occupancy Performance Level (S-1)

Immediate Occupancy is the post-earthquake damage state in which only very limited structural damage has occurred. In the primary concrete frames, there will be hairline cracking.

2.2) Damage Control Performance Range (S-2)

Structural Performance Range S-2, Damage Control, is the continuous range of damage states that less damage than that defined for the Life Safety level, but more than that defined for the Immediate Occupancy level.

2.3) Life Safety Performance Level (S-3)

Structural Performance Level S-3, Life Safety, is the post-earthquake damage state in which significant damage to the structure has occurred, but some margin against either partial or total structural collapse remains. In the primary concrete frames, there will be extensive damage in the beams. There will be spalling of concrete cover and shear cracking in the ductile columns

2.4) Limited Safety Performance Range (S-4)

Structural Performance Range S-4, Limited Safety is the continuous range of damage states between the Life Safety and Collapse Prevention levels

2.5) Collapse Prevention Performance Level (S-5)

Structural Performance Level S-5, Collapse Prevention, is the building is on the verge of experiencing partial or total collapse. In the primary concrete frames, there will be extensive cracking and formation of hinges in the ductile elements

Performance point – The performance point is the point where capacity curve crosses demand curve.

II. Data To Be Used

1. Material properties

Modulus of elasticity of concrete, $E_c = 22360 \text{ N/mm}^2$.

Grade of concrete = M20

Grade of steel = Fe-415

Poissons ratio of concrete = 0.2

2. Description of frame structure

The RC frame structure 5 stories 1 bay, 2 bay, 3 bay, 4 bay, 5 bays are considered in this study. In the modal, for 1 bay, the X- direction and Y-direction, each of 6m in length. For 2 bay, in X- direction is 12m and Y-direction is 6m in length. For 3 bay, in X- direction is 18m and Y-direction is 6m in length. For 4 bay, in X- direction is 24m and Y-direction is 6m in length. For 5 bay, in X- direction is 30m and Y-direction is 6m in length and the support condition was assumed to be fixed and soil condition was assumed as medium soil. All slabs were assumed as Membrane element of 150 mm thickness. The typical floor height is 3m. The details of beams and columns are shown in table 1. Live load on slab is 3 KN/m^2 . Frame is assumed as ordinary RC moment resisting frame (OMRF) and Zone is assumed as III.

Table 1 Specification

Beams	Columns
230X450mm	300X600mm

2.1. Zone Factor (Z)

Seismic Zone	II	III	IV	V
Seismic Intensity	Low	Moderate	Severe	Very Severe
Z	0.10	0.16	0.24	0.36

2.2 Importance Factor - I

2.3 Response Reduction Factor (R) for building system

Lateral load Resisting System	R
<i>Building Frame System</i>	3
1) Ordinary RC Moment Resisting Frame (OMRF)	

3. Plan of Structure

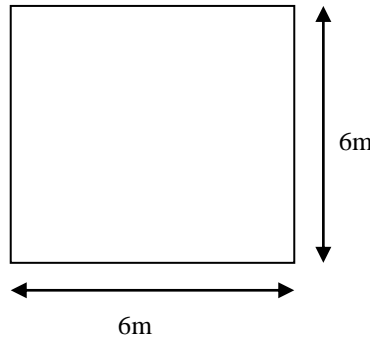

Fig C: plan of structure

III. Static Analysis Of Buildings Using Is 1893 (Part 1)-2002

- 1) Design Seismic Base Shear- The total design lateral force or design seismic base shear (Vb) along any principal direction of the building shall be determined by the following expression

$$V_B = A_h W$$

Where A_h = Design horizontal seismic coefficient.

W = Seismic weight of the building

- 2) Fundamental Natural Time Period:

The fundamental natural time period (Ta) calculates from the expression

$$T_a = 0.075h^{0.75} \text{ for RC frame building}$$

$$\text{For 5 storey, } T_a = 0.075 \times 15^{0.75} = 0.57 \text{ sec} \quad \text{where } h=15\text{m}$$

- 3) Distribution of Design Force-

The design base shear, V_B computed above shall be distributed along the height of the building as per the following expression

$$Q_i = V_B \frac{W_i h_i^2}{\sum_{j=1}^n W_j h_j^2}$$

IV. Pushover Analysis

The purpose of pushover analysis is to evaluate the expected performance of structural systems by estimating performance of a structural system by estimating its strength and deformation demands in design earthquakes. The evaluation is based on an assessment of important performance parameters, including global drift, interstory drift, inelastic element deformations (either absolute or normalized with respect to a yield value), deformations between elements, and element connection forces (for elements and connections that cannot sustain inelastic deformations). The inelastic static pushover analysis can be viewed as a method for predicting seismic force and deformation demands, which accounts in an approximate manner for the redistribution of internal forces that no longer can be resisted within the elastic range of structural behavior.

In pushover analysis after assigning all properties of the models, the displacement –controlled pushover analysis of the models are carried out. The models are pushed in monotonically increasing order until target displacement is reached or structure loses equilibrium. The program includes several built-in default hinge properties that are based on average values from ATC-40 for concrete members and average values from FEMA-273 for steel members.

- Locate the pushover hinges on model. ETABS provides hinge properties and recommends PMM hinges for columns and M3 hinges for beam as described in FEMA-356.
- Define pushover load cases. IN ETABS more than one pushover load case can be run in the same analysis.

V. Results And Graph

CASE 1: 5 stories 1bay, 5 stories 2bay, 5 stories 3bays (Zone – 3)

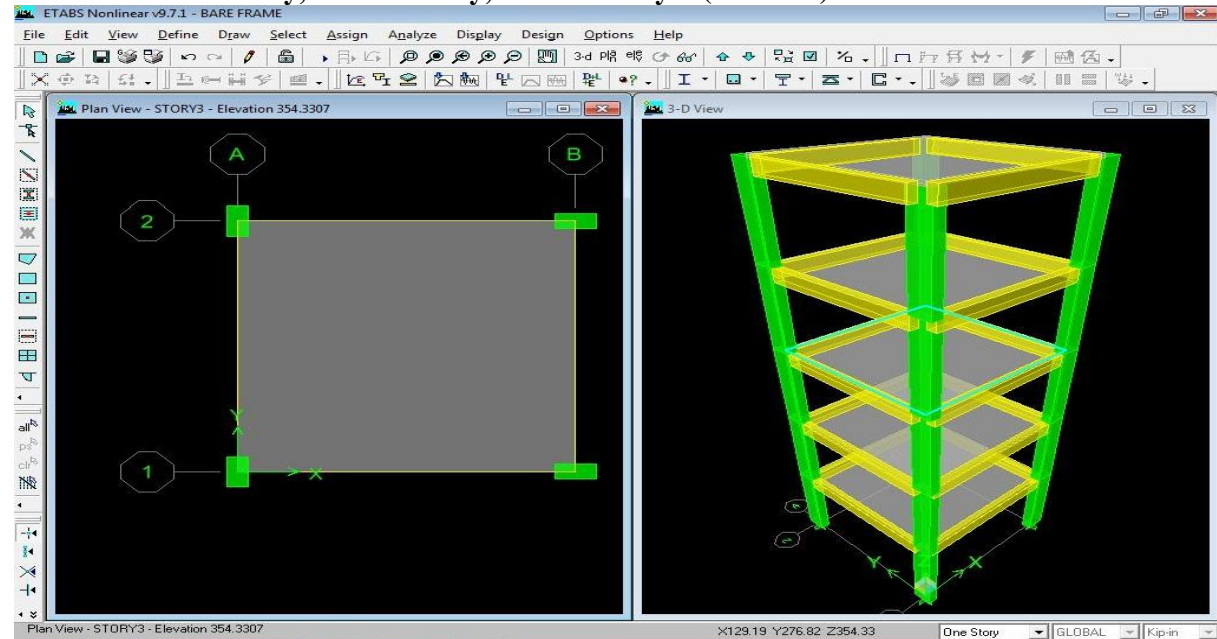

Fig D. Modeling of the structure – 5 storey 1 bay

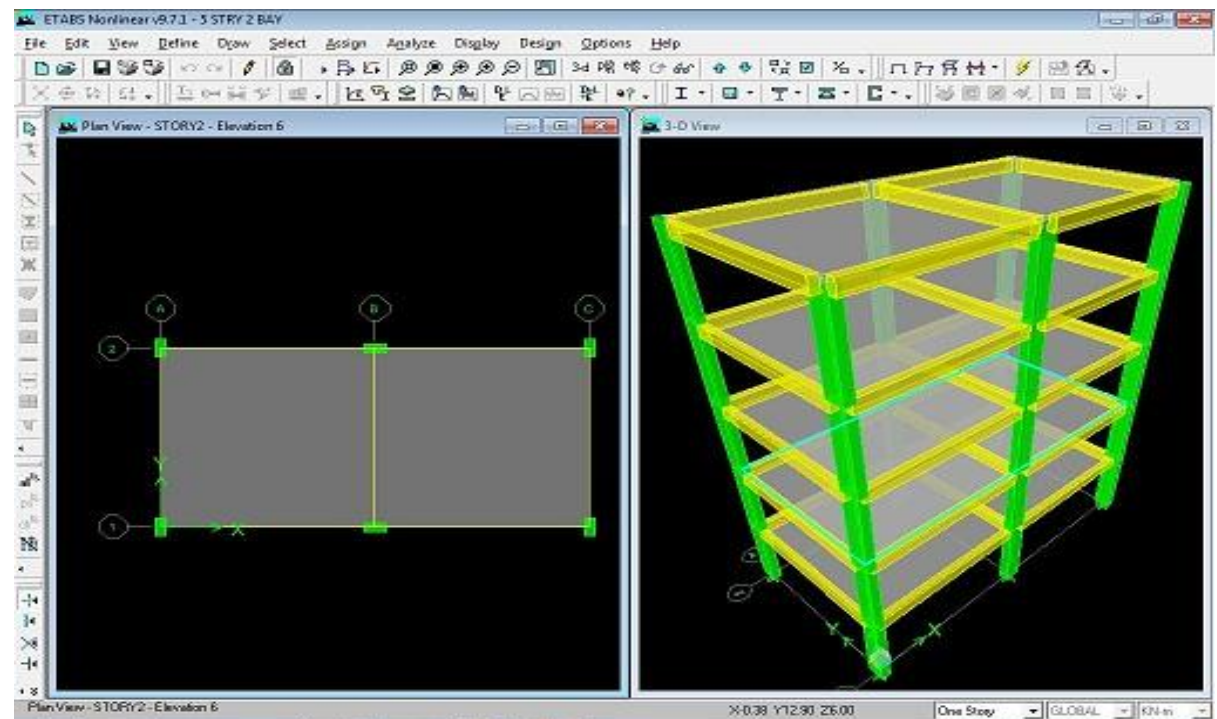

Fig E. Modeling of the structure – 5 storey 2 bays

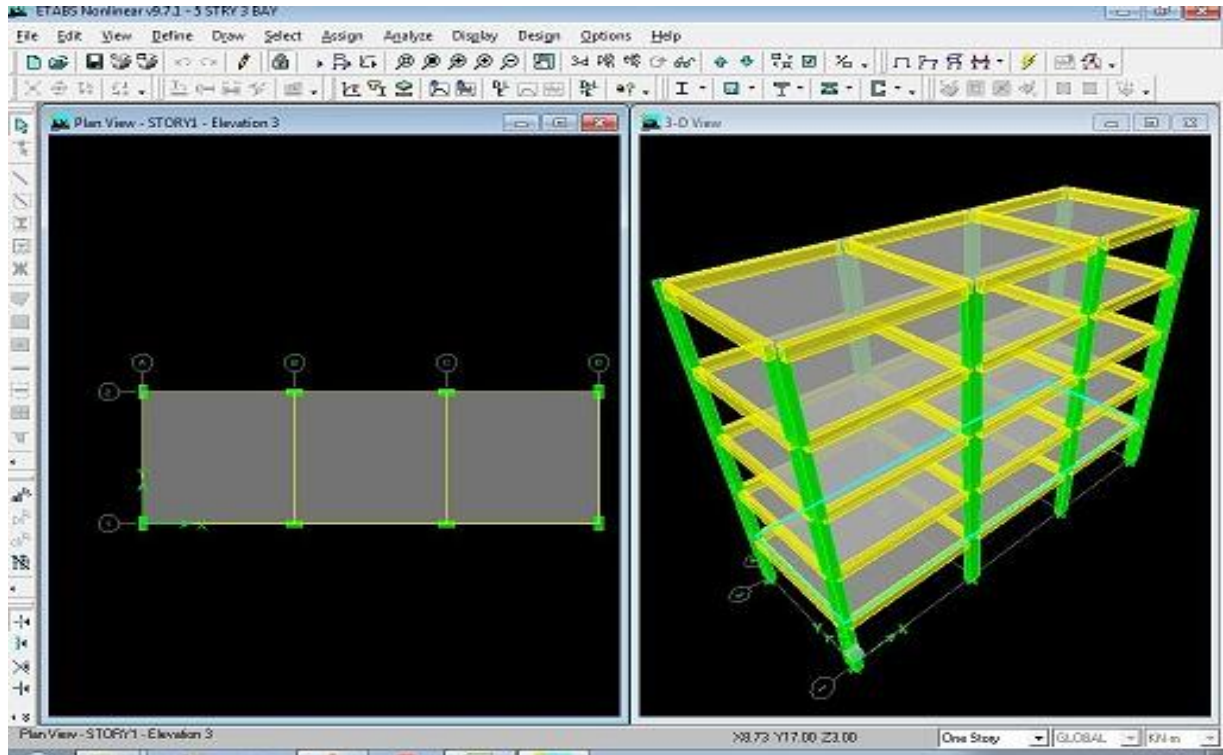

Fig F. Modeling of the structure – 5 storey 3 bays

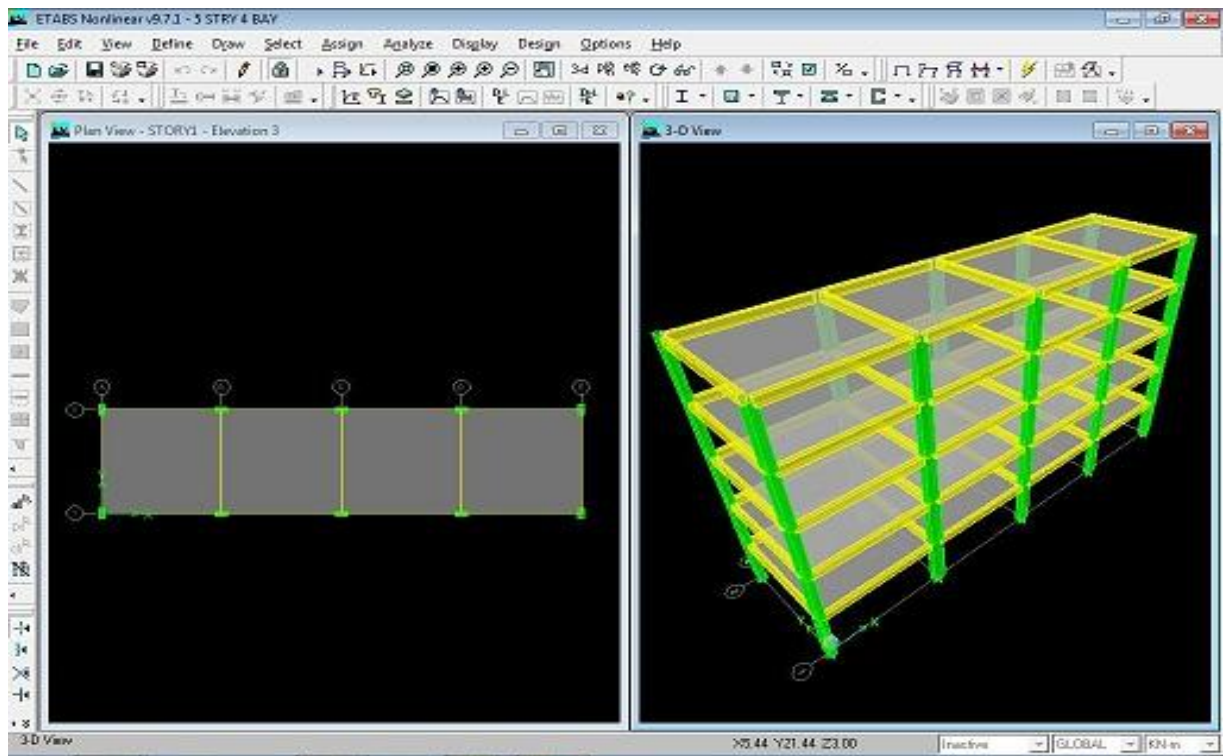

Fig G. Modeling of the structure – 5 storey 4 bays

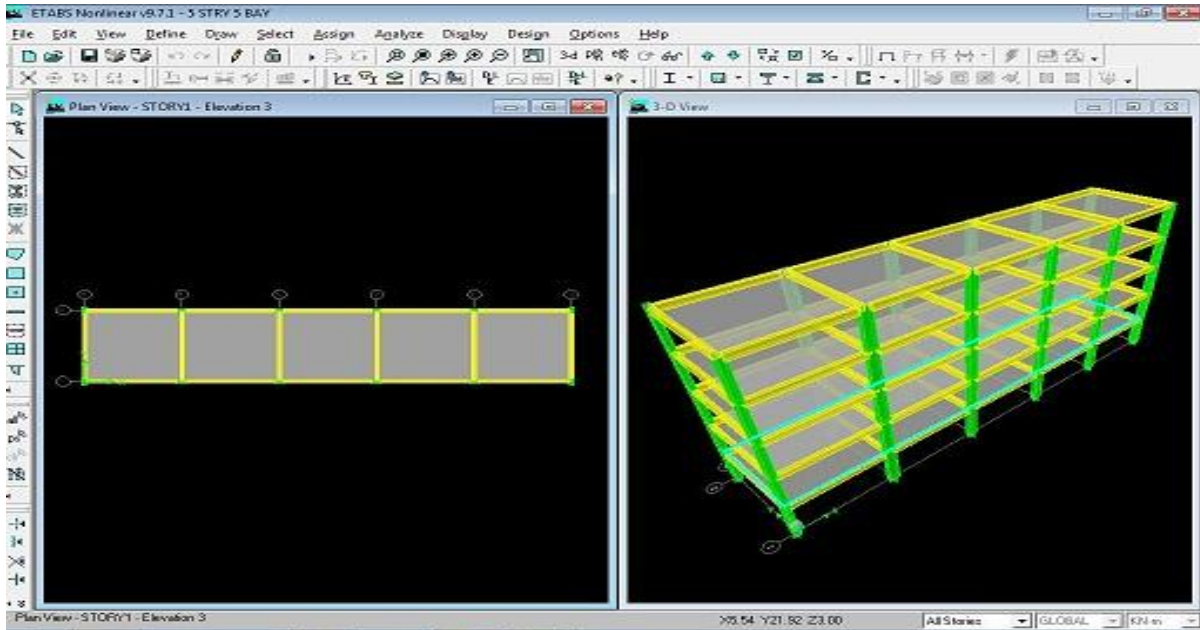

Fig H. Modeling of the structure – 5 storey 5 bays

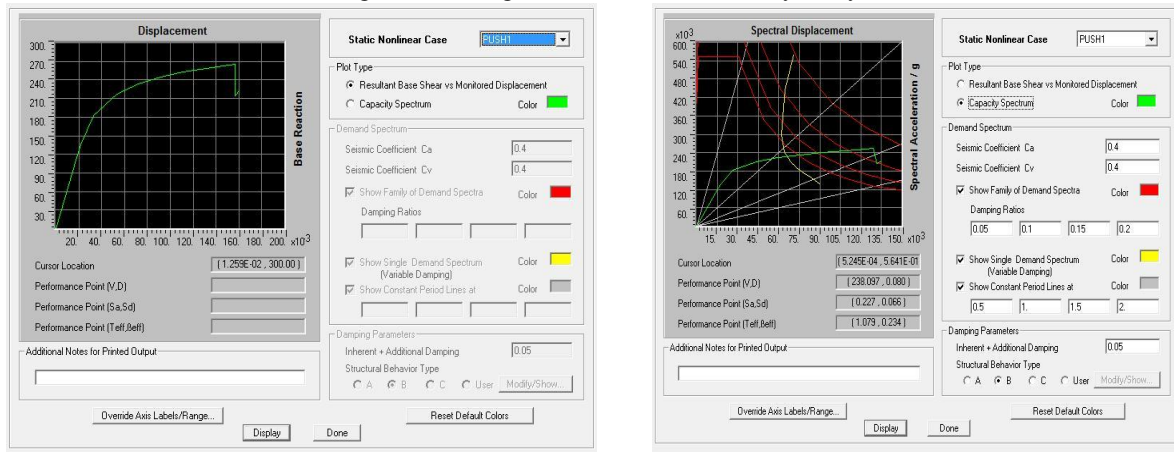

Fig I. Pushover curve and capacity spectrum curve of 5 storey 1 Bay frame structure

Table 2. Data of pushover curve – 5 storey 1 Bay frame structure

Steps	Displacement (m)	Base Force (KN)	A-B	B-IO	IO-LS	LS-CP	CP-C	C-D	D-E	>E	TOTAL
0	0.0000	0.0000	80	0	0	0	0	0	0	0	80
1	0.0180	114.0863	79	1	0	0	0	0	0	0	80
2	0.0214	135.3655	73	7	0	0	0	0	0	0	80
3	0.0326	181.9155	68	9	3	0	0	0	0	0	80
4	0.0531	217.1372	65	7	8	0	0	0	0	0	80
5	0.0718	233.2322	62	9	7	2	0	0	0	0	80
6	0.0919	244.7291	59	10	5	6	0	0	0	0	80
7	0.1115	252.7425	57	9	5	9	0	0	0	0	80
8	0.1415	261.3673	56	10	4	9	0	1	0	0	80
9	0.1566	265.1048	56	10	4	6	0	0	4	0	80
10	0.1566	213.8401	55	11	4	6	0	0	3	1	80
11	0.1605	224.0116	80	0	0	0	0	0	0	0	80

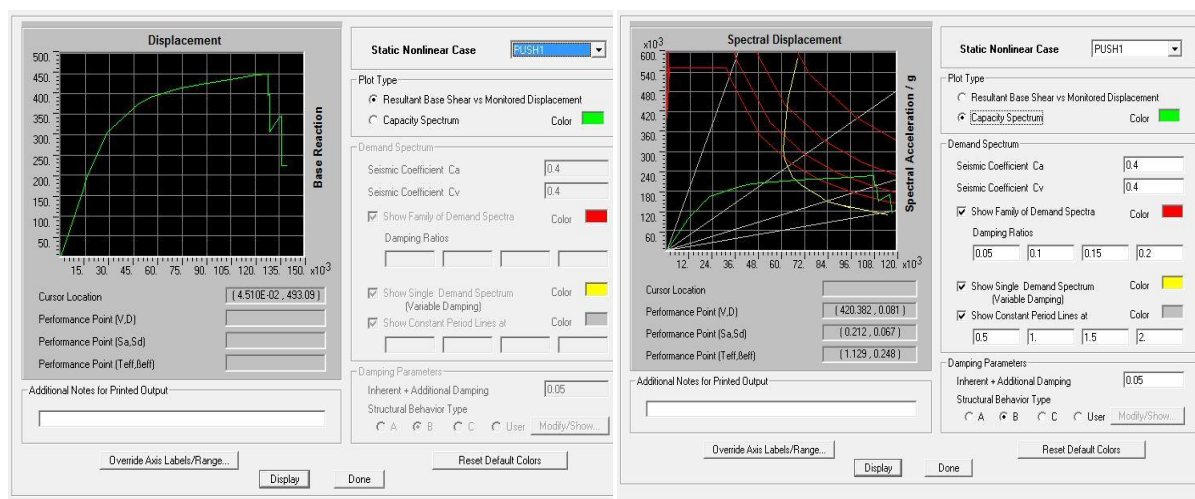

Fig J. Pushover curve and capacity spectrum curve of 5 storey 2 Bay frame structure

Table 3. Data of pushover curve – 5 storey 2 Bay frame structure

Step	Displacement (m)	Base Force (KN)	A-B	B-IO	IO-LS	LS-CP	CP-C	C-D	D-E	> E	TOTAL
0	0.0000	0.0000	130	0	0	0	0	0	0	0	130
1	0.0140	168.6583	128	2	0	0	0	0	0	0	130
2	0.0160	192.2338	118	12	0	0	0	0	0	0	130
3	0.0283	303.4860	110	16	4	0	0	0	0	0	130
4	0.0472	373.8783	106	16	8	0	0	0	0	0	130
5	0.0549	390.8734	100	18	10	2	0	0	0	0	130
6	0.0740	415.2544	98	10	14	8	0	0	0	0	130
7	0.0904	426.9975	98	12	10	10	0	0	0	0	130
8	0.1044	436.3230	94	14	10	12	0	0	0	0	130
9	0.1204	446.7271	94	14	6	14	0	2	0	0	130
10	0.1279	449.7834	92	16	6	14	0	0	2	0	130
11	0.1279	395.7111	92	16	6	12	0	2	2	0	130
12	0.1288	397.5452	90	16	8	10	0	0	4	2	130
13	0.1288	305.3375	90	16	8	10	0	0	4	2	130
14	0.1344	338.8262	88	18	8	10	0	0	4	2	130
15	0.1362	345.1073	88	18	8	10	0	0	2	4	130
16	0.1362	222.9465	88	18	8	10	0	0	2	4	130
17	0.1400	222.9922	130	0	0	0	0	0	0	0	130

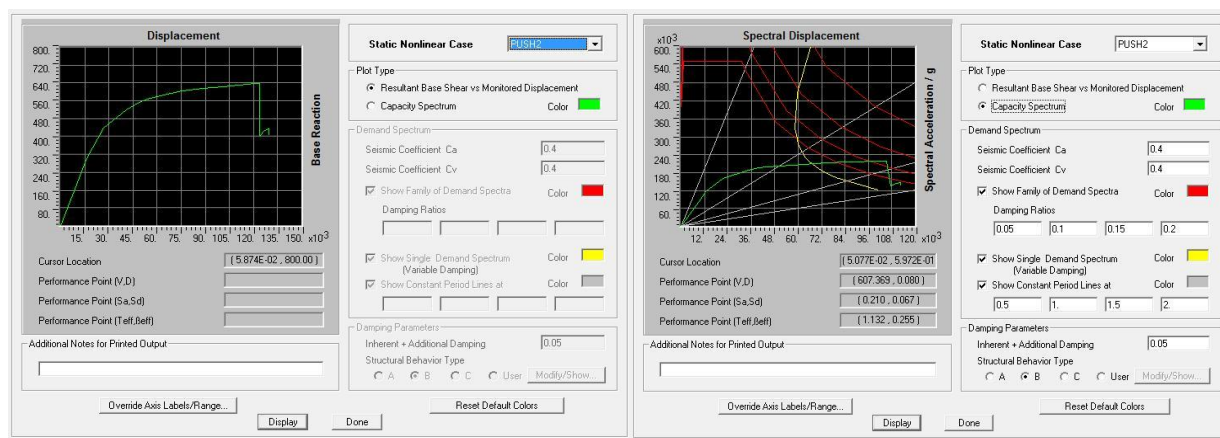

Fig K. Pushover curve and capacity spectrum curve of 5 storey 3 Bay frame structure

Table4. Data of pushover curve – 5 storey 3 Bay frame structure

Step	Displacement (m)	Base Force (KN)	A-B	B-IO	IO-LS	LS-CP	CP-C	C-D	D-E	> E	TOTAL
0	0.0000	0.0000	180	0	0	0	0	0	0	0	180
1	0.0130	243.1448	176	4	0	0	0	0	0	0	180
2	0.0162	303.0541	164	16	0	0	0	0	0	0	180
3	0.0269	437.0129	154	22	4	0	0	0	0	0	180
4	0.0408	519.5013	148	22	10	0	0	0	0	0	180
5	0.0486	552.9985	144	24	12	0	0	0	0	0	180
6	0.0540	568.5616	138	28	14	0	0	0	0	0	180
7	0.0686	593.1505	130	34	12	4	0	0	0	0	180
8	0.0754	603.5259	130	22	16	12	0	0	0	0	180
9	0.0884	614.0777	130	20	16	14	0	0	0	0	180
10	0.1014	624.6293	126	22	12	20	0	0	0	0	180
11	0.1204	636.7278	126	22	12	16	0	4	0	0	180
12	0.1236	638.5013	122	22	16	12	0	0	4	4	180
13	0.1236	402.5017	118	26	16	12	0	0	4	4	180
14	0.1271	426.0541	118	26	16	12	0	0	2	6	180
15	0.1296	435.1704	118	26	16	12	0	0	2	6	180
16	0.1296	407.8596	118	26	16	12	0	0	2	6	180
17	0.1300	408.0432	180	0	0	0	0	0	0	0	180

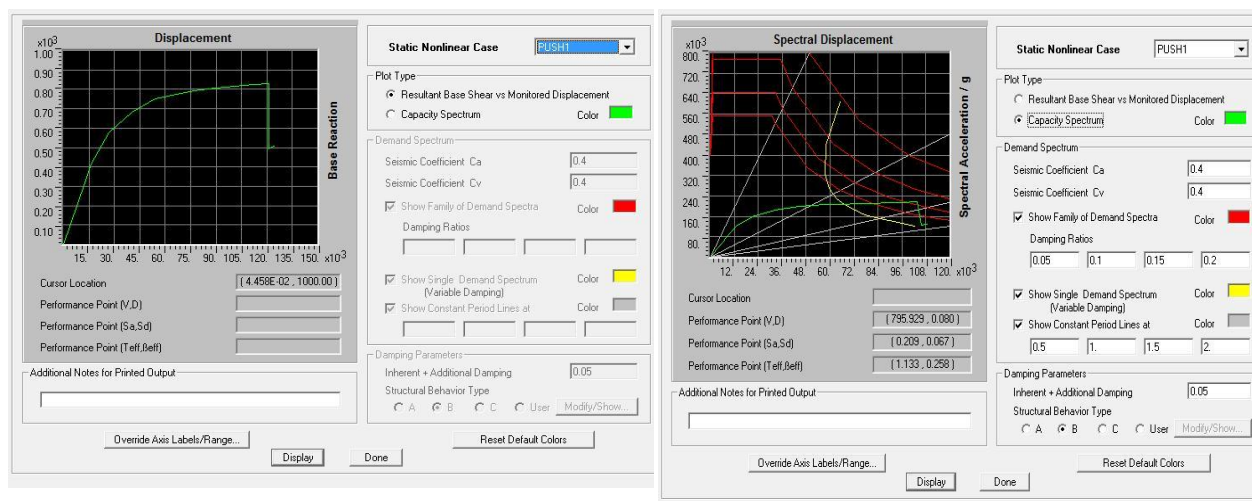

Fig K. Pushover curve and capacity spectrum curve of 5 storey 4 Bay frame structure

Table4. Data of pushover curve – 5 storey 4 Bay frame structure

Step	Displacement (m)	Base Force (KN)	A-B	B-IO	IO-LS	LS-CP	CP-C	C-D	D-E	> E	TOTAL
0	0.0000	0.0000	230	0	0	0	0	0	0	0	230
1	0.0125	316.9172	224	6	0	0	0	0	0	0	230
2	0.0164	415.8301	208	22	0	0	0	0	0	0	230
3	0.0265	574.4053	196	28	6	0	0	0	0	0	230
4	0.0402	682.1976	182	32	16	0	0	0	0	0	230
5	0.0542	749.7209	176	36	12	6	0	0	0	0	230
6	0.0691	779.2498	162	36	26	6	0	0	0	0	230
7	0.0770	793.5040	162	30	20	18	0	0	0	0	230
8	0.0895	805.3311	158	32	16	24	0	0	0	0	230
9	0.1123	823.7858	158	32	14	20	0	6	0	0	230
10	0.1213	830.0909	152	32	20	16	0	0	4	6	230
11	0.1214	493.7753	148	38	20	16	0	0	4	6	230
12	0.1239	505.4902	148	38	20	16	0	0	4	6	230
13	0.1250	506.8337	230	0	0	0	0	0	0	0	230

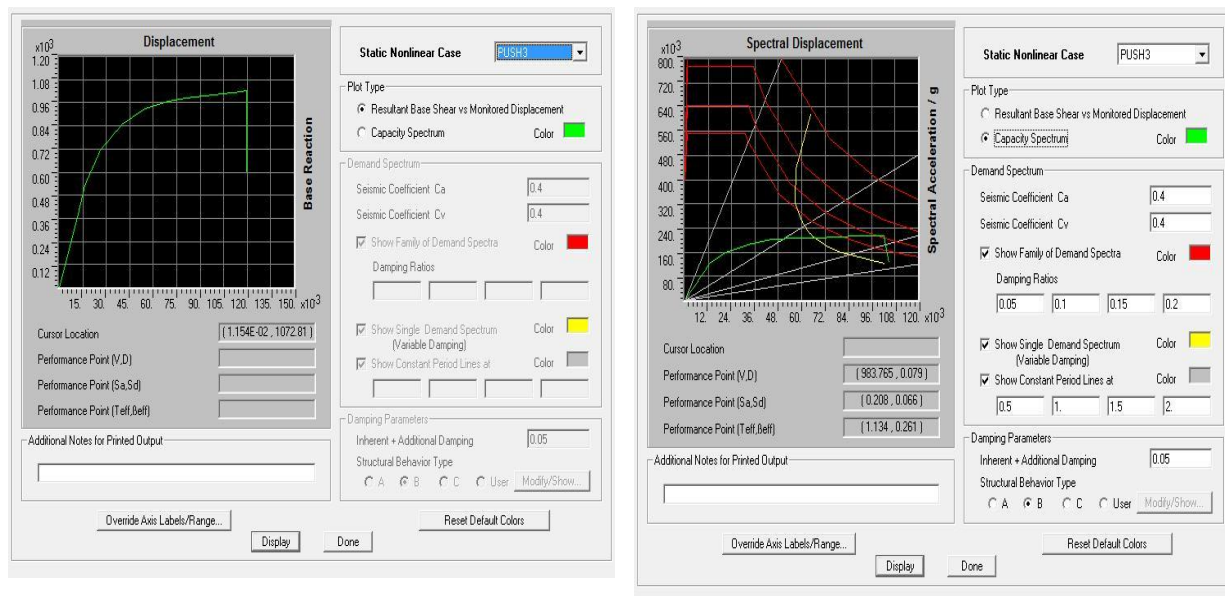

Fig L. Pushover curve and capacity spectrum curve of 5 storey 5 Bay frame structure

Table4. Data of pushover curve – 5 storey 5 Bay frame structure

Step	Displacement (m)	Base Force (KN)	A-B	B-IO	IO-LS	LS-CP	CP-C	C-D	D-E	> E	TOTAL
0	0.0000	0.0000	280	0	0	0	0	0	0	0	280
1	0.0120	384.0114	272	8	0	0	0	0	0	0	280
2	0.0165	528.4146	252	28	0	0	0	0	0	0	280
3	0.0263	711.7445	238	34	8	0	0	0	0	0	280
4	0.0399	844.9644	220	40	20	0	0	0	0	0	280
5	0.0544	931.3446	212	46	14	8	0	0	0	0	280
6	0.0699	966.0086	194	44	30	12	0	0	0	0	280
7	0.0807	986.4946	190	40	28	22	0	0	0	0	280
8	0.1044	1009.0944	190	40	18	32	0	0	0	0	280
9	0.1164	1019.1423	190	36	22	24	0	8	0	0	280
10	0.1196	1021.8544	182	36	30	20	0	0	4	8	280
11	0.1196	602.8223	180	38	30	20	0	0	4	8	280
12	0.1200	605.3279	280	0	0	0	0	0	0	0	280

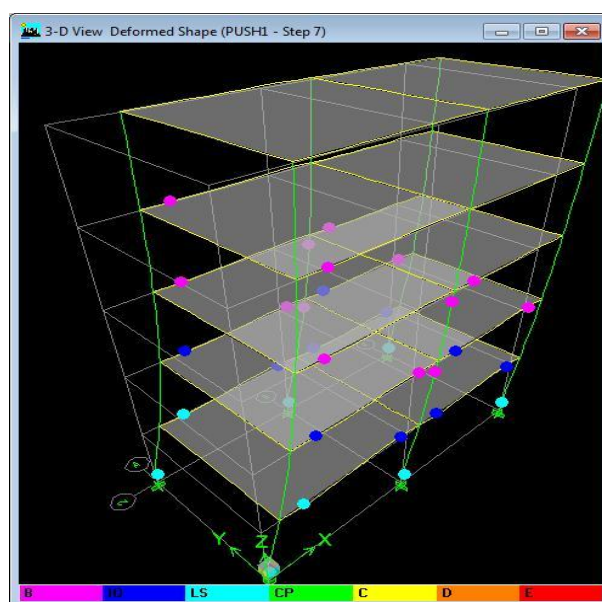
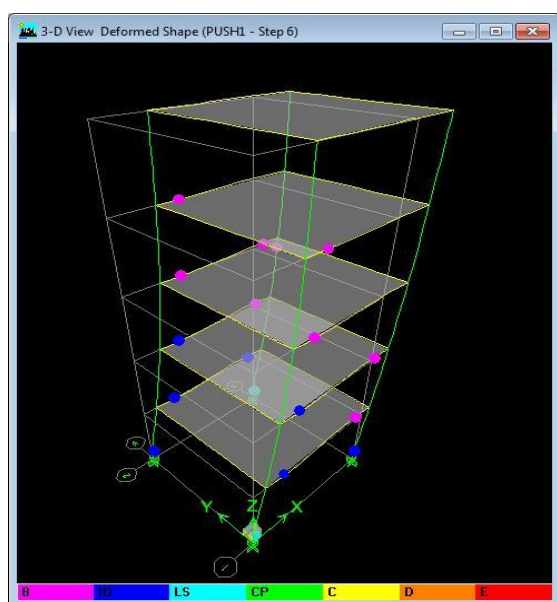

Fig M. Formation of Plastic hinges at step 6 Fig N. Formation of Plastic hinges at step 7

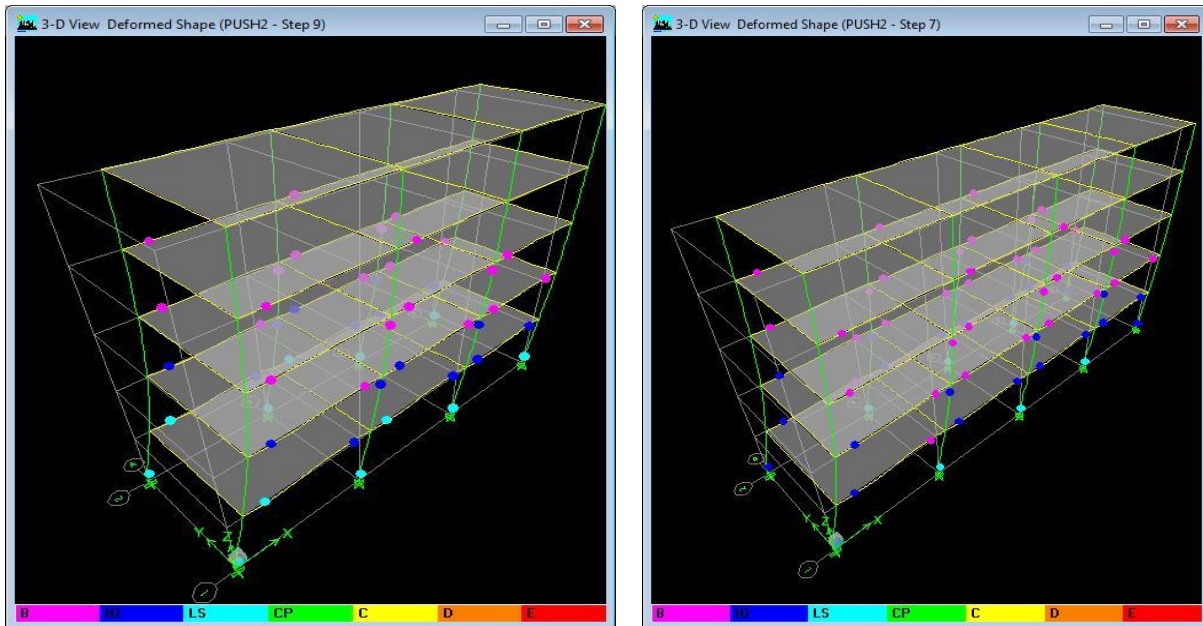

Fig O. Formation of Plastic hinges at step 8 Fig P. Formation of Plastic hinges at step 7

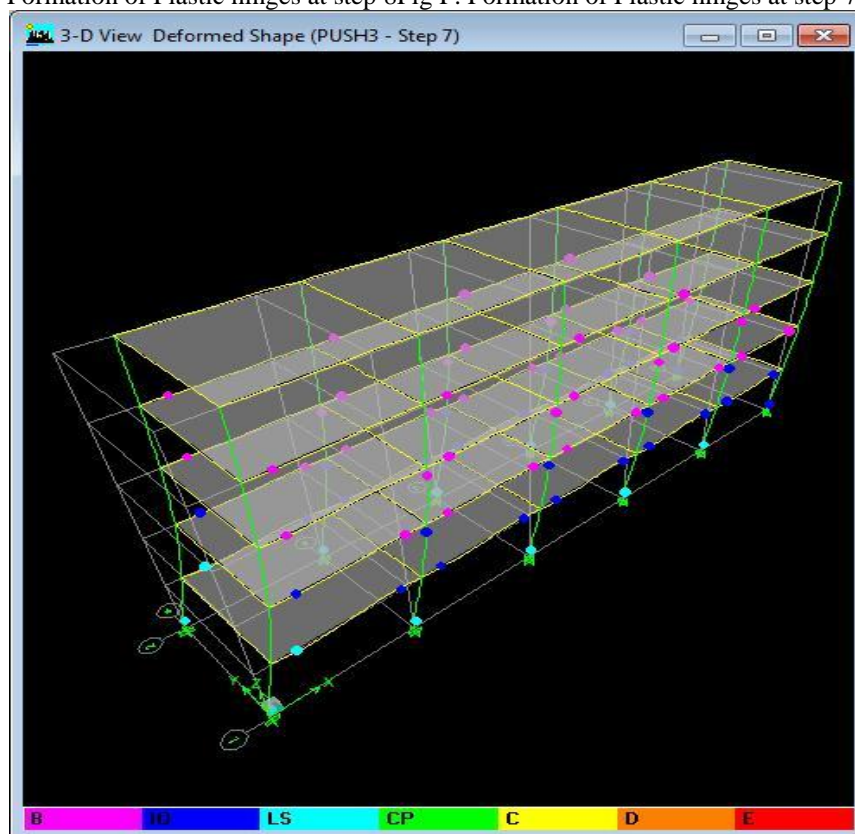
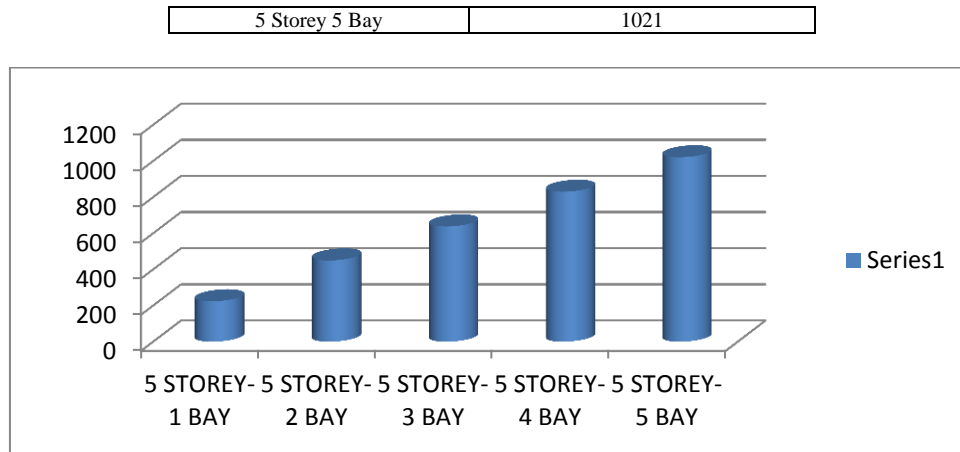

Fig Q. Formation of Plastic hinges at step 7

V1. Comparison Of Maximum Base Force And Displacement Of 5,10,15Storeys

Table5. Maximum base force of 5 Storey 1 Bay,2 Bay,3 Bay,4 Bay,5 Bay

STOREYS	MAXIMUM BASE FORCE (KN)
5 Storey 1 Bay	224
5 Storey 2 Bay	450
5 Storey 3 Bay	638
5 Storey 4 Bay	830



Graph 1. Comparison of maximum base force of 5, 10, 15 storey

Table 6. Maximum displacement of 5, 10, 15 storey

STOREYS	MAXIMUM DISPLACEMENT (mm)
5 Storey 1 Bay	16
5 Storey 2 Bay	14
5 Storey 3 Bay	13
5 Storey 4 Bay	12.5
5 Storey 5 Bay	12

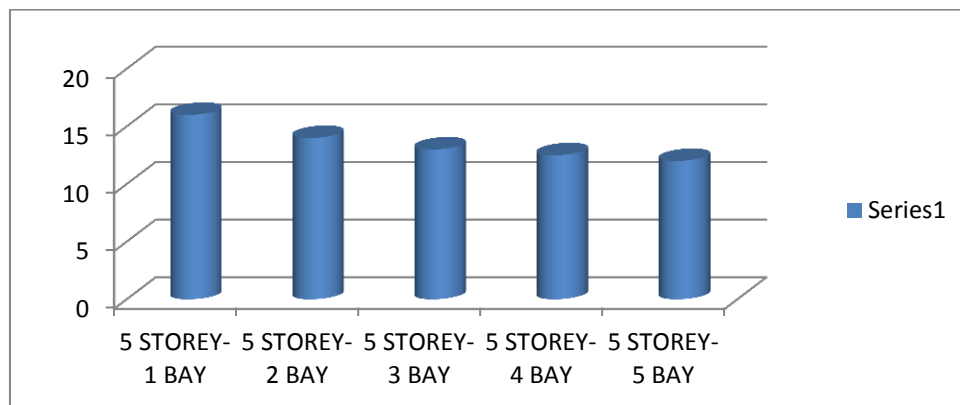

Graph 2. Comparison of maximum displacement of 5, 10, 15 storey

VII. Conclusions

The performance of reinforced concrete frame was investigated using pushover analysis. These are the conclusions drawn from the analysis:

- Pushover analysis is a solution for complicated problems of estimating the capacity and deformation problems for certain types of structures.
- In 5 storey 1 bay frame structure, pushover analysis was including 11 steps. It has been observed that, on subsequent push to building, hinges started forming in beams first. Initially hinges were in B-IO stage and subsequently proceeding to IO-LS and LS-CP stage. At performance point, where the capacity and demand meets, out of 80 assigned hinges 59 were in A-B stage, 10, 5, and 6 hinges are in BIO, IO-LS and LS-CP stages respectively. As at performance point, hinges were in LS-CP range, overall performance of building is said to be Life safety to Collapse prevention level.
- In 5 storey 2 bay frame structure pushover analysis was including 17 steps. At performance point, where the capacity and demand meets, out of 130 assigned hinges 98 were in A-B stage, 10, 4, and 8 hinges are in BIO, IO-LS and LS-CP stages respectively. As at performance point, hinges were in LS-CP range, overall performance of building is said to be Life safety to Collapse prevention level.
- In 5 storey 3 bay frame structure pushover analysis was including 17 steps. At performance point, where the capacity and demand meets, out of 180 assigned hinges 130 were in A-B stage, 34, 12 and 4 hinges are in BIO, IO-LS and LS-CP stages respectively. As at performance point, hinges were in LS-CP range, overall performance of building is said to be Life safety to Collapse prevention level.

- In 5 storey 4 bay frame structure pushover analysis was including 13 steps. At performance point, where the capacity and demand meets, out of 230 assigned hinges 162 were in A-B stage, 30, 20 and 18 hinges are in BIO, IO-LS and LS-CP stages respectively. As at performance point, hinges were in LS-CP range, overall performance of building is said to be Life safety to Collapse prevention level.
- In 5 storey 5 bay frame structure pushover analysis was including 12 steps. At performance point, where the capacity and demand meets, out of 280 assigned hinges 190 were in A-B stage, 40, 28 and 22 hinges are in BIO, IO-LS and LS-CP stages respectively. As at performance point, hinges were in LS-CP range, overall performance of building is said to be Life safety to Collapse prevention level.
- The RC bare frame which is analyzed for the static non linear pushover cases, 5 storey 1 bay frame can carry lower base force and at higher displacement it fails
- The RC bare frame which is analyzed for the static non linear pushover cases, 5 storey 5 bay frame can carry higher base force and at lower displacement it fails.

References

- [1] Santhosh D, Pushover Analysis of RC frame structure using ETAB 9.7.1, IOSR journal of mechanical and civil engineering (IOAS-JMCE)– volume 11 issue 1-Feb 2014.
- [2] Srinivasu A and Dr.Panduranga Rao.B, Non-Linear static analysis of multi-storied building, International journal of engineering trends and technology(ILETT) – volume 4 issue 10-oct 2013.
- [3] Mrugesh D. Shah, Nonlinear static analysis of RCC frames(software implementation ETABS 9.7),National conference on recent trends in engineering & technology-May 2011
- [4] Chopra AK.Dynamics of structure: theory and application to earthquake engineering.(ERnglewood cliffs,NJ:1995)
- [5] IS 1893(part 1):2002, Criteria for earthquake resistant design of structures, Part 1 General provisions and buildings, Bureau of Indian standard,2002.