

## **Cold Energy Recovery and Utilization of LNG-Powered Refrigerated Transport Ships**

Li Jun, Zheng Tian, Chen Yu

(College of Mechanical and Automotive Engineering, Shanghai University Of Engineering Science, Shanghai, China, 201620)

---

**Abstract :** Due to the environmental advantages of LNG powered ships, they have attracted more and more attention from the society. LNG-powered refrigerated transport ships are a form of LNG-powered ships. The LNG gasification process releases a large amount of cold energy, which provides the required cooling for the ship's cold storages, and then saves a large amount of electricity for the compression refrigeration device. HYSYS software simulates the feasibility of providing LNG cold energy to ship's normal temperature cold storages and low temperature cold storages, and analyzes the required LNG and refrigerant flow under the premise of the required cold storage volume.

**Keywords :** LNG-powered ship, Cold energy, Cold storages

---

Date of Submission: 15-01-2020

Date of Acceptance: 03-02-2020

---

### **I. Introduction**

In China, diesel is the main fuel for ships, which mainly composed of hydrocarbons and some other elements. Diesel combustion releases large amounts of carbon dioxide, sulphide, nitride and dust, which can put great pressure on the environment<sup>[1]</sup>. The use of natural gas as a clean fuel in marine applications began in Norway in the late 1990s. In 2016, Comprehensive work plan for energy conservation and emission reduction during the 13th five-year plan period clearly stated that vigorously promote liquefied natural gas-powered ships and other environmentally-friendly vehicles, and strive to achieve national sulfur oxide (SO<sub>x</sub>) and nitrogen oxide (NO<sub>x</sub>) emissions by 2020 Total volume is 15% lower than 2015<sup>[2]</sup>. At present, on LNG dual fuel ships, natural gas is stored in a liquid state. When used, it is directly heated and vaporized by seawater or engine cooling water, and the temperature rises to a certain temperature before entering the engine combustion<sup>[3]</sup>. LNG under a certain pressure has a large amount of cold exergy and pressure exergy. If it is converted into electricity with 100% efficiency, each ton of LNG can convert 250kWh of electricity. Therefore, Using LNG cold energy technology to power LNG ships can not only reduce operating costs for shipping companies, but also avoid waste of energy and truly achieve energy conservation and environmental protection.

#### **1. Feasibility of using LNG cold energy on ships**

At present, most domestic and foreign scholars study the application of LNG cold energy in ground receiving stations. The cold energy of LNG can be used for air separation, low-temperature power generation, low-temperature pulverization, carbon dioxide recovery, seawater desalination, cold storages, air conditioning, and recreational facilities such as ski resorts, and determined the principle of "temperature counterpart and step utilization". For LNG powered ships, the cold energy utilization plan should take into account the characteristics of the ship different from the ground application and the specific needs of the ship. If the cold energy released by the LNG gasification process is used for its refrigerated transportation, it will save a lot of energy consumption for electric refrigeration. For ocean-going ships, it is also a practical problem to ensure that the crew has enough fresh water for a long voyage. Using LNG cold energy to desalinate seawater by freezing is a successful desalination technology on the ship. In addition, LNG cold energy can also be used in ship's air-conditioning systems to provide a relatively comfortable working and living environment for people on ships.

#### **2. LNG cold energy based on HYSYS for cold storage refrigeration**

Using LNG as fuel, refrigerated transport ships have a large number of cold storages, they have conventional refrigeration system. Now it is hoped that the cold energy of LNG to refrigerate each cold storages. The basic technical conditions for scheme design are as follows: 1) LNG inlet temperature is -163°C; 2) The

temperature of the cold storage room is  $-25^{\circ}\text{C}$  and  $+2^{\circ}\text{C}$ . The two cold storages are each designed according to the cooling capacity of 20kW. 3) R404a is used as the refrigerant in the cold storage; 4) LNG initial component (molar component) and storage conditions are:  $\text{CH}_4$ :  $\text{C}_2\text{H}_6$ :  $\text{C}_3\text{H}_8$  is 0.97: 0.02: 0.01, storage temperature is  $-163^{\circ}\text{C}$ , and storage pressure is 1.4 bar.

Traditional cold storages using the compression refrigeration equipment to maintain the low temperature of the cold storages, and the power consumption is large. It is a good way to use the cold energy by recycling the cold energy of LNG to supply the cold storage. The LNG and the refrigerant are exchanged in a low-temperature heat exchanger, and the cooled refrigerant enters a freezer or a refrigerator through a pipe, and then releases the cold energy through a cooling coil to freezing of goods. At this time, the cold storage does not use a refrigerator, which saves a lot of initial investment and operating freight, and can also save about 1/3 of electricity.

According to the initial technical conditions, process simulation is performed. The specific form and node parameters are shown in Figure 1.

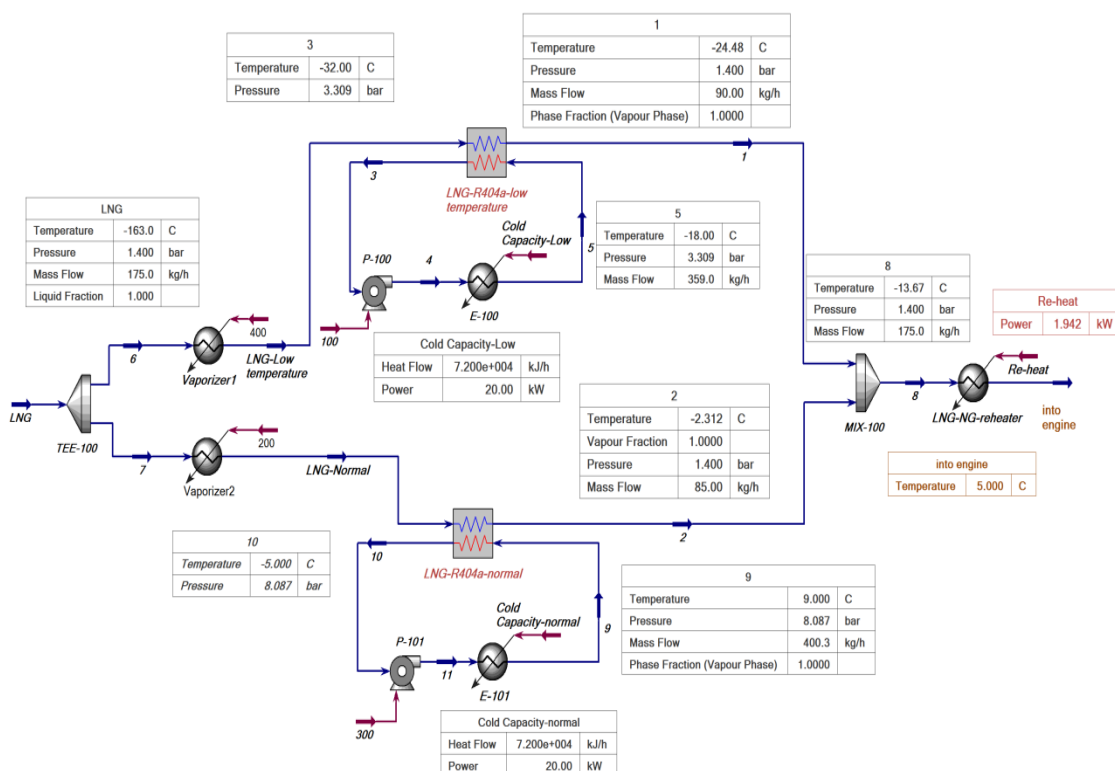

Fig. 1 HYSYS process simulation diagram

LNG exchanges heat in parallel with the refrigerants in the low-temperature storages and normal-temperature storages to maintain the low-temperature environment of the cold storages ; In the design of the process, a heating link for LNG is added, and the heat exchange temperature difference between LNG and the refrigerant can be adjusted by adding heat, a heat exchanger should be introduced.

From the results of the process simulation, it can be seen that in order to ensure that the normal temperature storage and the low temperature storage each have a cooling capacity of 20kW, the total flow of LNG entering the system is required to reach 175 kg/h. the heat exchange rate with the room temperature storage is 85 kg/h. The temperature of NG after mixing is  $-13.67^{\circ}\text{C}$ . It is necessary to add a re-heater or introduce exhaust steam from the power plant to reheat and enter the engine. When the NG temperature is required to be maintained at  $5^{\circ}\text{C}$ , the reheating required by the system is 1.942kW. The refrigerant flow required by the low-temperature storage is 359 kg/h, and the refrigerant flow required by the normal-temperature storage is 400.3 kg/h.

## II. Conclusion

1) It is a reasonable way to use the cold energy of LNG in cold storage, which not only reduces the initial investment cost of system equipment, but also recovers a large amount of LNG gasification cold energy, which significantly reduces the electricity consumption of cold storage.

- 2) The recoverable cooling capacity released by the LNG gasification station can fully meet the cooling needs of large-capacity cold storage, and the cold storage system has a simple structure and a short investment recovery period.
- 3) The designed LNG cold energy is used in the process of the cold storage system. Combining cold storage technology with freezing technology can ensure the stable and safe operation of the cold storage room.
- 4) The cooling capacity of the cold storage is 20kW, and the total LNG flow required is 175kg/h, of which the LNG flow exchanged with the low temperature storage is 90 kg/h, and the flow exchanged with the normal temperature storage is 85 kg/h.
- 5) The flow rate of refrigerant R404a in low temperature storage is 359 kg/h, and that in normal temperature storage is 400.3 kg/h.

### **References**

- [1]. Yu Xiang, Li Shanheng, Duan Yulong, The rise of LNG-powered ships and the recovery and reuse of cold energy, *China Water Transport*, 2012, 12 (11), 9-10
- [2]. Wu Yan, Duan Zhaofang, Analysis of the Development Status and Related Problems of LNG Power Ships, *China Energy*, 2017, 39 (8), 36-38
- [3]. Hu Xuanzhe, Sun Wenzhe, Gu Xiaoyong, Hou Long, Feng Mengjiao, Simulation and Optimization of Cold Energy Generation System for LNG Powered Ships, *Ship Engineering*, 2015, 37 (2), 50-53

Li Jun, Zheng Tian, et al. "Cold Energy Recovery and Utilization of LNG-Powered Refrigerated Transport Ships". *IOSR Journal of Mechanical and Civil Engineering (IOSR-JMCE)*, 17(1), 2020, pp. 18-20.