

Tensioner Pulley Actuated Flywheel Speed Increaser for Run-off (ROR) and Direct River (DR) Hydropower and Wind Power Generation

¹Abdulmalik Onuwe I., ²Garba Mahmood. M., ³Chukwu Uche P., ⁴Aminu Saleh, ⁴Habibu Ismail, ²Koko A. A. N. and ³Amony Michael C.

¹*Hydraulic Equipment Development Institute, National Agency for Science and Engineering Infrastructure, Federal Ministry of Science and Technology, Abuja.*

²*Sokoto Energy Research Centre, Energy Commission of Nigeria, Usman Danfodiyo University, Sokoto.*

³*National Board for Technology Incubation (NBTI), Federal Ministry of Science and Technology, Abuja.*

⁴*Institute for Agricultural research (IAR), Agricultural and Water Resources Engineering Department, Ahmadu Belo University, Zaria.*

Corresponding Author: mikeamonye@gmail.com

Abstract: *In conventional hydropower installations, a dam is placed across a river to create a reservoir. All (or almost all) of the water is impounded behind the dam and the flow downstream is channeled to drive the turbine which in turn rotates an Alternator or Dynamo to generate electricity. Wind and Water turbine alternators are made to generate electricity at low speeds as the natural forces would achieve. These alternators are constructed with Permanent Magnets (PM) and able to generate electricity at speeds as low as 50 Rpm. In large Hydropower systems, very huge PM alternators are specifically constructed at huge cost to harness the water energy into electricity. But the loss of aquatic habit, harm to fish populations as well as a significant change in natural flow regimes and deterioration of the landscape occasioned by conventional hydropower systems has led to alternative development of Run-off River (ROR) and Direct River (DR) systems which maintain ecological stability while providing portable power to remote locations. ROR installation is where the water is diverted upstream at a natural gradient and used to drive a typically small turbine. The DR is where the Hydro turbine is installed on stanchions casted on the riverbed allowing the force of flowing water to drive the turbine. These novel machines come in as Small, Micro and Pico Hydro turbines accompanied by prevalent low speed of hydro turbines. The low speed cannot generate power when transmitted to available Synchronous generators, PMs and Dynamos as a result of the latter's higher speed demand. This has hindered the development and proliferation of small hydropower systems in Nigeria. There is therefore the need for a Speed Multiplier to increase the speed to the rated revolution of the alternators. This is the problem which this invention is created to solve.*

Keywords: *Hydro, Power, Speed, Multiplier, Alternator, Electricity.*

Date of Submission: 15-03-2022

Date of Acceptance: 31-03-2022

I. Introduction

Before 1960, the bulk of power production in Nigeria was from coal as the source of fuel for thermal power system. Construction activities on the first hydropower station in Nigeria commenced in 1964 at Kainji on River Niger. The dam was commissioned in 1968 with an installed capacity of 320MW, and by 1978, the station had 8 plants with capacity of 760MW. Later on, the tail water from Kainji Dam was utilized to generate 540MW at Jebba Dam, 97 km downstream of Kainji Dam. The third Hydro-Electric Power (HEP) station, the Shiroro Dam was commissioned in 1990 with an installed capacity of 600MW bringing the total installed capacity of Hydro Electric Power (HEP) in Nigeria to 1900MW. There are a number of small hydropower stations, such as 3MW plant in Bagel, 8MW plant in Kura and 8MW in Lere, 2MW Station at Kwall fall on N'Gell River (River Kaduna) and 8MW station at Kurra fall. The cumulative capacity of hydropower stations (small and large) is about 2000 MW. This accounts for 32% of the combined installed capacity of hydro, thermal and gas power stations in Nigeria. The development of 2500MW Mambilla hydropower station is in progress and the country still has potential for about 6000MW hydropower stations. Nigeria has just developed 23% of her feasible hydropower. This is very low compared to other African countries such as Lesotho which has developed 50% of her hydropower potential; Burkina Faso developed 46%, while Kenya has developed 34% of her hydropower potential (Abaka *et al.*, 2017).

There is an increasing need to develop clean energy technologies to cope with the problems relating to climate change, sustainable development, and energy security. Although hydropower is currently the principal renewable electricity generation source, its development would require overcoming some barriers concerning environment, public acceptance, and economic aspects. Contrary to apparent benefits, large scale hydroelectric development produces a broad range of environmental impacts. Chief among these impacts are landscape destruction, contamination of food webs by mercury, and possibly the evolution of greenhouse gases (Rosenberg *et al.*, 1995). Very small hydro plants do not suffer from such environmental and social problems as larger ones generally due to the scale of the technology the insignificant storage of water. Normally these schemes do not form a barrier to the passage of aquatic life, especially fish.

Mini, micro and pico hydropower are now recognized as key technologies in bringing renewable electricity to rural populations in developing countries, many of whom do not have access to electric power. A recent report on electrification technologies by the World Bank Energy Unit shows that, of the options currently available for off-grid generation, pico hydro is likely to have the lowest cost. For mini-grid power, probably only biogas plants provide more cost-effective electricity than micro hydro. (Edeoja *et al.*, 2015). These small hydro systems are delivered economically through River diversion called Run off River (ROR) or through Direct River (DR) installations without building Dams and challenging the ecology. Economic benefits and environmental sustainability are typical reasons why interest in run-of-river hydropower plants is increasing. Climate change, shortage of appropriate places to build conventional hydropower plants, or generating electricity as near as possible to the consumption site (distributed generation) are other reasons for considering this type of plants (Sarasúa *et al.*, 2014).

ROR hydro plants have become more important in recent years. Such plants are characterized by the small or zero storage capacity of the head pond and therefore the generated energy depends to a great extent on the available flow in the river. Typical advantage of ROR over conventional storage systems is that it allows harnessing the energy associated with water flows for other uses, such as water supply or irrigation, or the environmental minimum flows. Also in most cases, conventional hydro plants with reservoir give rise to significant environmental effects, such as physical barriers for fish movements or sediments transport along the river, visual impact, flooded areas, and land use issues (Sarasúa *et al.*, 2014). Small, Micro and Pico hydro as achieved through ROR and DR; engender positive social impacts. There is a greater potential for active participation of the beneficiaries and the associated social benefits from rural electrification using these smaller hydro than with other technologies. In addition, since large damming is unnecessary, the displacement of inhabitants and restructuring of livelihoods are avoided. (Edeoja *et al.*, 2015).

The primary electrical and mechanical components of a hydro plant are the turbine and the alternator. The turbine is the shaft-baffle assembly rotated by the force of moving water. The alternator or generator is the electrical component that generates electricity when coupled to a turbine. It is the machine that converts the mechanical energy of the turbine to electrical energy. The power that can be produced by an alternator is determined by the alternator rating. The input of the alternator is speed dependent. It means that, the higher the speed of rotation of the alternator shaft, the more power the alternator produce. The speed of an alternator depends on the speed of the engine or turbine driving it. (Mazlan *et al.*, 2017). The rated speeds of available alternators are significantly above the Revolutions per minute (Rpm) transmitted by the water and wind powers. This is the bane of small hydropower and wind turbine systems as they require large turbine's rotational speed to deliver power. The speed vary from 1000 to 1,500 Rpm. A contrivance for enhancing the speed is required to be installed between the turbine and the Alternator to achieve electricity at the alternator output. For speed reduction or increase in mechanical systems, mechanical components such as gearbox, gear reducers, chain and belt drives are the components of choice depending on the desired objective. In hydro and wind turbine utilization the interest is the reduction of energy losses in the transmission.

Power loss in the gearbox is mostly due to friction, which generates heat. In miniature gearboxes, heat is not much of a problem because the power losses and the absolute amounts of power involved are relatively small. However, large gearboxes use oil coolers and pumps to compensate for gearbox inefficiency. Thus, gearbox efficiency depends on friction. This in turn depends on the quality of the gearing, the number of tooth engagements (how many times one wheel drives another) and the load torque (how much "moment" the gearbox has to deliver). Most manufacturers will specify an intended gearbox operating point. Gearbox efficiencies in a spur gearbox at a 16-mm diameter vary from about 87% at a gear ratio of 6.3:1 to about 40% at a ratio of 10,683:1. A basic rule that designers use for spur gears is a 10% loss per engagement. One gear wheel in contact with another is defined as an engagement and the loss in that engagement is approximately 10%. (Faulhaber, 2012). It is also known, that chain transmissions have comparatively high values of transmission efficiency (92 ... 97%) (Egorov *et al.*, 2015).

The major portion of belt energy loss during power transmission is attributed to parasitic bending hysteresis and sliding friction. The cogged construction which minimizes the hysteretic component of parasitic loss yields the greatest efficiency in each industrial test. Median efficiency of the surveyed industrial and

agricultural belt types and constructions is 96 per cent. Within rated and application power levels, transmission belt efficiency ranges from 90 to 99 per cent depending on belt type, construction, and application parameters (Breig and Oliver 1980). The foregoing shows that belt transmission components are preferred option for speed increase in hydro or wind turbine systems for the reduction in energy loss, characteristic of the drive.

II. Flywheel

A flywheel (Plate 1) is a rotating disk that stores energy as kinetic energy. The faster the flywheel spins the more kinetic energy it stores. The concept of a flywheel is as old as the axe grinder’s wheel, but could very well hold the key to tomorrow’s problems of efficient energy storage. The flywheel has a bright outlook because of the recent achievement of high specific energy densities. A simple example of a flywheel is a solid, flat rotating disk. A flywheel is an inertial energy-storage device. It absorbs mechanical energy and serves as a reservoir, storing energy during the period when the supply of energy is more than the requirement and releases it during the period when the requirement of energy is more than the supply. The main function of a fly wheel is to smoothen out variations in the speed of a shaft caused by torque fluctuations. If the source of the driving torque or load torque is fluctuating in nature, then a flywheel is usually called for. Many machines have load patterns that cause the torque time function to vary over the cycle. Internal combustion engines with one or two cylinders are a typical example. Piston compressors, punch presses, rock crushers, etc. are the other systems that have flywheels. Due to its high density, low cost and excellent machinability, gray cast iron ASTM 30 is often used to make the flywheel, whose properties are listed in Table 1. (Bawane *et al.*, 2012).

The flywheel can be used as an energy reservoir, with energy being supplied at a slow constant rate or when it is available and being withdrawn when desired. A flywheel might, for example, be used to give good acceleration to an automobile that is underpowered by present standards. Regenerative breaking, power storage for peak-demand periods, and mechanical replacements for battery banks are all potential uses for the flywheel. The high charging and discharging rates of a flywheel system give it an advantage over other portable sources of power, such as batteries. The purpose of energy-storage flywheels is to store as much kinetic energy, $0.5J\omega^2$, as possible. In most applications, the flywheel speed does not vary over 50 percent, so that only about 75 percent of this total energy is actually recoverable. The design of the ordinary flywheel is usually dictated by the allowable diameter, governed by the machine size, and the maximum speed, governed by the practicalities of a speed increasing drive and higher bearing speeds. (Curtis, 2004).



Plate 1: Flywheel

Energy moving in and out of the flywheel can be used to provide temporary and constant power. A flywheel’s greatest benefit is in equipment where the main power source is provided in unsteady bursts. By using conservation of energy, the flywheel stores energy as it is being released from the main power source in a surge or burst. As the main source of energy decreases, the energy stored in the flywheel is released. The kinetic energy stored in a flywheel is proportional to the mass and to the square of its rotational speed according to Eq. (1). (Bolund et al 2007).

$$E = \frac{1}{2} I\omega^2 \dots\dots\dots (1).$$

Where ‘E’ is kinetic energy stored in the flywheel, ‘I’ is moment of inertia and ‘w’ is the angular velocity of the flywheel.

Table 1: Material and Properties of Conventional Flywheel

Material, Class, specification	Gray cast iron, ASTM 30, SAE 111
--------------------------------	----------------------------------

Ultimate strength	Tension, Sut= 214Mpa; shear sut – 303 MPa
Torsional shear strength	270Mpa
Modulus of elasticity	Tension, E = 101 GPa, shear, G = 41 GPa
Density	7510kg
Poisson's ratio	0.23.

III. Statement of the Problem

Energy generation in Nigeria is poor, notwithstanding the large hydropower potential of the country. Gigantic Dams and civil works are not necessarily the best way to harness hydropower giving its cost and ecological disadvantages. Run-off River and Direct River systems employing small and micro hydro components appear the best sustainable options. These turbines deliver rotational speeds lower than the rated speeds of available alternators in Nigeria. The absence of an equitable speed increaser to take motion from the turbine and transmit to the alternator at its rated speed is the bother of smaller hydropower development and proliferation in Nigeria. The problem is readily solved by the application of this invention.

IV. Belt Tensioner

Belt tensioners are idler wheels that are typically mounted to spring mechanisms or an adjustable pivot point, which keeps the right amount of constant tension on the serpentine belt of your vehicle. The belt tensioner in this invention employs the threaded shaft-Nut Assembly shown in figure 1. The peculiar behaviour of the contrivance is that when the shaft is rotated in a stationary position, the nut moves linearly along the shaft length. When a pulley is attached to the 'Nut' of the contrivance, its linear motion in either direction on the turning of the threaded shaft is used to put the tension or release the belts. The Tensioner is depicted in figure 2.

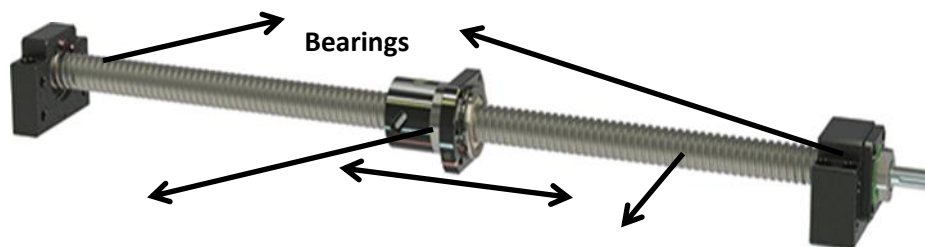

Figure 1: Threaded Shaft-Nut Assembly

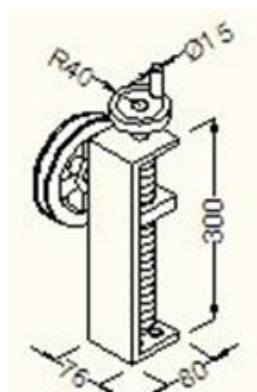
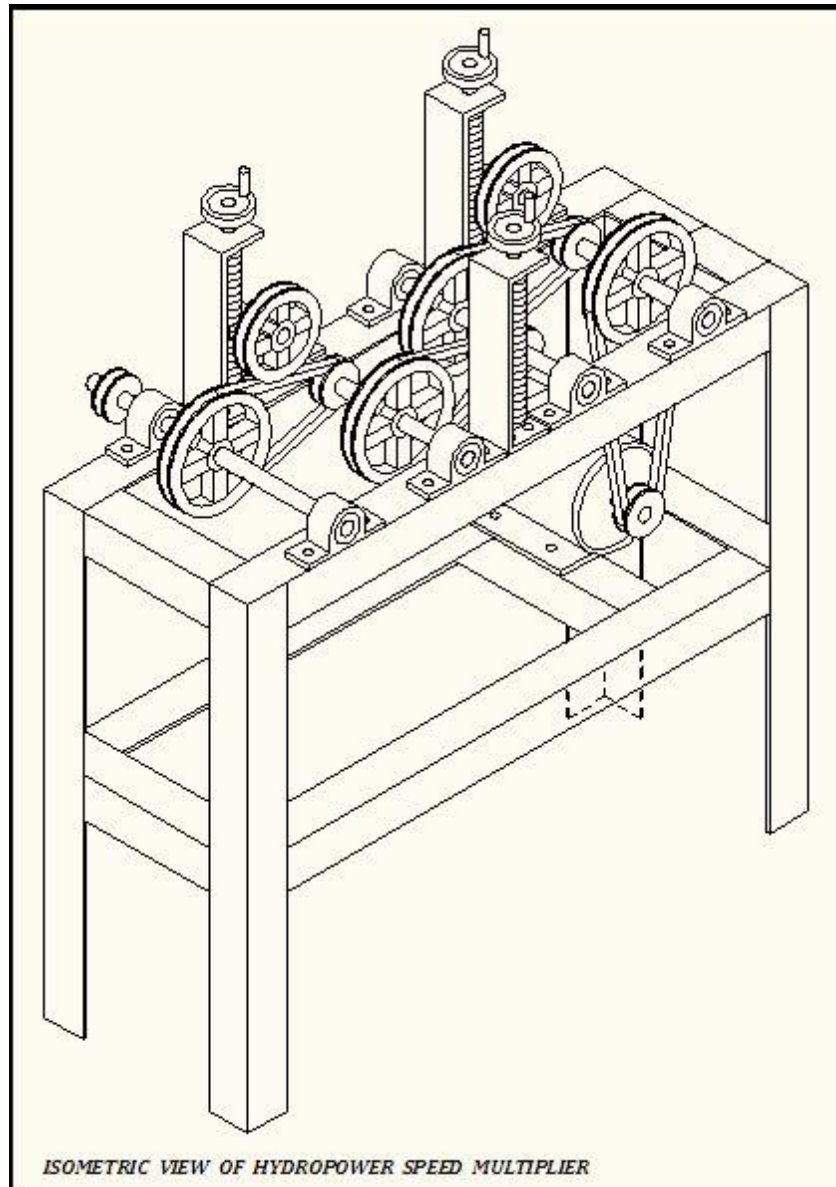

Figure 2: Belt Tensioner

V. The Innovation

The contrivance consists of parallel flywheel carrying shafts on bearings linking motion to each other through V-pulleys and belts. Input motion from a low speed hydro or wind turbine enters the first shaft. In the series of shafts the preceding shaft carries a bigger pulley which inputs motion onto the small pulley of the following shaft. Thus each shaft carries a small receiving pulley and a bigger motion transmitting pulley resulting in increasing speed from the preceding shaft to the following shaft. The speed of the last shaft is increased tremendously above the speed of the first shaft. Tensioner pulleys are used for actuating and disengaging the motion while the energy conserved by the flywheels maintain the shafts running at set speeds at the alternator or load output end. The actuation employing the Tensioner Pulleys is as follows: motion from the

low speed wind or hydro turbine is connected to the first shaft which runs very slowly and negligible in power to do meaningful work. On getting steady motion of the first shaft, the Tensioner Pulley is used to engage it to the second shaft which runs faster than the first shaft. The same process continues until the speed required at the alternator or load output end is attained. Appendixes 1-3 are the isometric, orthographic and exploded views of the invention.



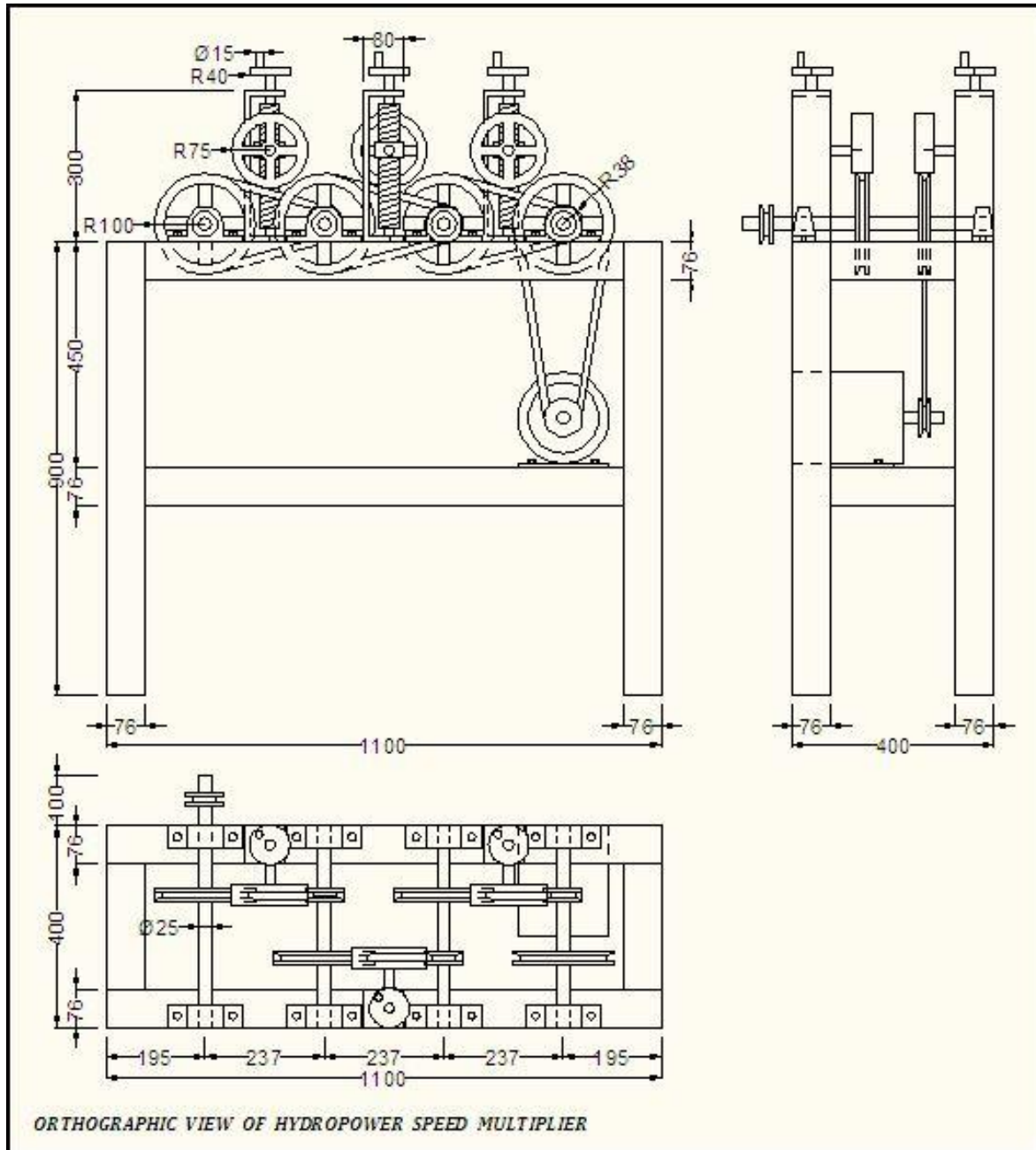

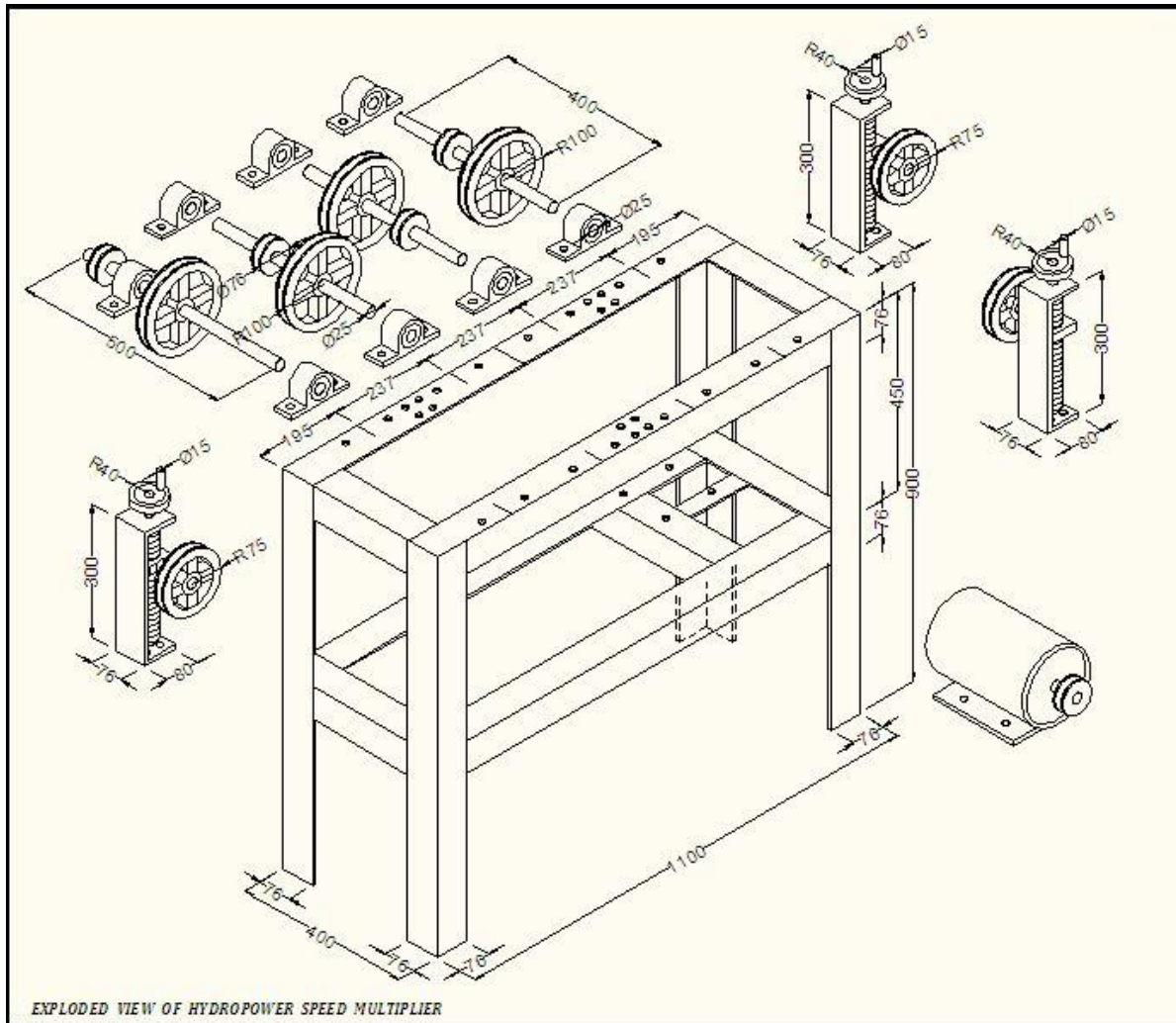

VI. Conclusion

The benefits of the flywheel to conserve energy and release it as the load demands is put to application when tensioner pulleys are gradually engaged to start successive flywheels till the required power and speed is attained at the output alternator. Thus available components in Nigeria can be employed at low cost to harness wind and hydropower without the need for imported very costly permanent magnet alternators. The project is a tripartite collaboration of Sokoto Energy Research Centre, Energy Commission of Nigeria, Usman Danfodiyo University, Sokoto, Hydraulic Equipment Development Institute, National Agency for Science and Engineering Infrastructure, Federal Ministry of Science and Technology, Abuja and National Board for Technology Incubation (NBTI), Federal Ministry of Science and Technology, Abuja. With scholarly input from Institute for Agricultural research (IAR), Agricultural and Water Resources Engineering Department, Ahmadu Belo University, Zaria.

Reference

- [1]. Edeoja A., Ibrahim S., and Kucha E. (2015). Suitability of Pico-Hydropower Technology for Addressing The Nigerian Energy Crisis – A Review. *International Journal of Engineering Inventions*, Volume 4, Issue 9; p. 18-24.
- [2]. Basar M. F. and Othman M. M. (2017). An Overview of the Key Components in the Pico Hydro Power Generation System. ISBN: 978-1-61804-175-3; p. 206.
- [3]. Abaka J. U., Ibraheem T. B., Salmanu H. and Olojede O. (2017). Hydropower Potential of Nigeria. *International Journal of Modern Engineering Research*; ISSN: 2249–6645, p. 53.
- [4]. Faulhaber F. (2012). A second look at Gearbox efficiencies. Published by Engineering MicroMo Clearwater, Fla.
- [5]. Sarasúa J. I., Elías P., Martínez-Lucas G., Pérez-Díaz J. I., José Román Wilhelmi J. R. and Sánchez J. A. (2014). Stability Analysis of a Run-of-River Diversion Hydropower Plant with Surge Tank and Spillway in the Head Pond. *Scientific World Journal* Volume, Article ID 874060, pp. 1-2.
- [6]. Mazlan R. K., Reduan M. D., Zakaria M. Z. and Hamid A. A. (2017). Experimental study on the effect of alternator speed to the car charging system. *MATEC Web of Conferences* 90 01076; p. 2.
- [7]. Höhn B. R., Michaelis K. and Hinterstoiber M. (2009). Optimization of Gearbox Efficiency. *Goriva I Maziva*; 48, 4, ISSN 0350-350X, p. 463.

- [8]. Breig W. F. and Oliver L. R (1980). Energy loss and efficiency of power transmission belts. Energy Loss and Efficiency of Power Transmission Belts. Third World Energy Engineering Congress; p. 1.
- [9]. Rosenberg D. M, Bodaly R. A. and Usher P. J. (1995). Environmental and social impacts of large scale hydroelectric development: who is listening? Global Environmental Change Vol. 5. No 2, p. 127.
- [10]. Egorov A., Kozlov K and Belogusev V. (2015). A Method for Evaluation of the Chain Drive Efficiency. Journal of Applied Engineering Science, 13-4, 341; p. 277.
- [11]. Taiwo A. M., Olujimi O. O., Bamgbose O. and Arowolo T. A. (2012). Surface Water Quality Monitoring in Nigeria: Situational Analysis and Future Management Strategy. InTech Janeza Trdine 9, 51000 Rijeka, Croatia; pp. 302-307.
- [12]. Zainuddin H., Yahaya M. S., Lazi J. M., Basar M. F. M. and Ibrahim Z. (2009). Design and Development of Pico-hydro Generation System for Energy Storage Using Consuming Water Distributed to Houses. World Academy of Science, Engineering and Technology 59, p. 154.

Abdulmalik Onuwe I, et. al. "Tensioner Pulley Actuated Flywheel Speed Increaser for Run-off (ROR) and Direct River (DR) Hydropower and Wind Power Generation". *IOSR Journal of Mechanical and Civil Engineering (IOSR-JMCE)*, 19(2), 2022, pp. 14-21.