

Satellite Image Enhancement Using Framelet Transform And Non-Local Means Filter

D.Febia Angelin¹, Dr.T.K Shanthi²

¹ (P.G Scholar, Applied Electronics, Thanthai Periyar Government Institute of Technology, Vellore, Tamil Nadu, India)

² (HOD,ECE Department, ThanthaiPeriyar Government Institute of Technology, Vellore, Tamilnadu, India)

Abstract: Resolution enhancement (RE) schemes suffer from the drawback of losing high frequency contents (which results in blurring). The wavelet-transform-based RE scheme, generates artifacts (due to a shift-variant property). Therefore a framelet-domain approach and non-local means (NLM) filter is proposed for RE of the satellite images. A satellite input image is decomposed by Framelet transform (FT) to obtain high-frequency subbands. The high-frequency subbands and the low-resolution (LR) input image are interpolated using the Lanczos interpolator. The high frequency subbands are passed through an NLM (despite of its nearly shift invariance). The filtered high-frequency subbands and the LR input image are combined using inverse FT to obtain a resolution-enhanced image. Objective and subjective analyses reveal superiority of the proposed technique over the RE techniques.

Keywords: Framelet Transform, Wavelet Transforms, Resolution Enhancement, Lanczos Interpolator, Shift variant

I. Introduction

The quality of image is degraded by various noises in its acquisition and transmission. Image De-noising has remained a fundamental problem in the field of image processing and enhancement. Therefore resolution of the image also gets degraded due to the effects of noise in the image. Resolution is the limiting factor for the utilization of remote sensing data like satellite image, it has been frequently referred as an important aspect of an image, therefore images are being processed using transforms and interpolation technique to obtain more enhanced resolution. Resolution enhancement schemes which are not based on wavelet transform namely frequency domain and time domain transform loses high frequency contents and leads to blurring of the image and wavelet transforms such as discrete wavelet transform(DWT) and dual tree complex wavelet transform is used(DT-CWT) has the disadvantage of coefficient noises and attributed to shift variance[1]. Therefore framelet transform(FT) is used. One of the commonly used techniques for image resolution enhancement is Interpolation; it has been widely used in many image processing applications such as image enhancement, facial reconstruction, multiple description coding, and super resolution. There are three well known interpolation techniques, namely nearest neighbor interpolation, bilinear interpolation, and bicubic interpolation, but lanczos interpolation is used here for image enhancement as it is more efficient [2]. Non-local means filter is used for denoising the transformed image. The system of resolution enhancement consist of framelet transform(FT) to which the low resolution image is fed, where they are decomposed into high frequency sub-bands and low frequency sub-bands. These decomposed image is interpolated using the interpolation factor and then the enhanced image is passed through inverse framelet transform and filtered using non-local means filter to remove the artifacts created by the transform and the high resolution image is obtained.

II. Transform Techniques

2.1 Wavelet transform

There are many types, such as continuous wavelet transform, discrete wavelet transform[3][4], stationary wavelet transform[5], Dual tree complex wavelet transform(DT-CWT). DT-CWT is more efficient when compared to all other transforms. Dual Tree-Complex Wavelet transform-The dual-tree CWT comprises of two parallel wavelet filter bank trees that contain filters of different delays that minimize the aliasing effects due to down-sampling. The dual-tree CDWT of a signal $x(n)$ is implemented using two critically-sampled DWTs in parallel on the same data. The transform is two times expansive because for an N-point signal it gives 2N DWT coefficients[6]. If the filters in the upper and lower DWTs are the same, then no advantage is gained. So the filters are designed in a specific way such that the sub-band signals of the upper DWT can be interpreted as the real part of a complex wavelet transform and subband signals of the lower DWT can be interpreted as the imaginary part. DTCWT calculates the complex transform of a signal using two separate DWT decompositions

(tree *a* and tree *b*). If the filters used in one are specifically designed different from those in the other it is possible for one DWT to produce the real coefficients and the other the imaginary.

III. Proposed Technique

3.1. Framelet Transform

The proposed technique is the framelet transform which eliminates coefficient noises and is effectively shift invariant when compared to DT-CWT. Framelet transform is similar to that of wavelet transform but has some differences. Framelets has two or more high frequency filter banks, which produces more subbands in Decomposition. This can achieve better time frequency localization. There is redundancy between the Frameletsubbands, where change in coefficients of one band can be compensated by other subbands coefficients. After framelet decomposition, the coefficient in one subband has correlation with coefficients in the other subband, which means that changes on one coefficient can be compensated by its related coefficient in reconstruction stage which produces less noise in the original image[7]. The block diagram of framlet transform is given in fig 1.

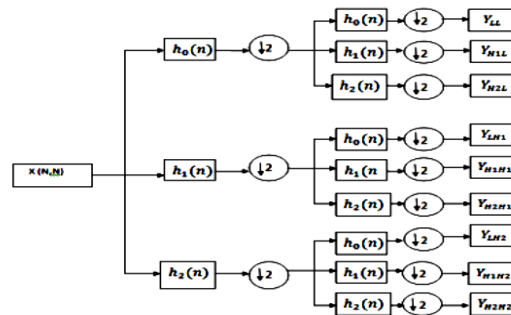

Figure 1: Framelet Transform

IV. Lanczos Interpolation

Lanczos resampling is a mathematical formula used to smoothly interpolate the value of a digital signal between its samples. It maps each sample of the given signal to a translated and scaled copy of the Lanczos kernel, which is a sinc function windowed by the central hump of a dilated sinc function. The sum of these translated and scaled kernels is then evaluated at the desired points. Lanczos resampling is typically used to increase the sampling rate of a digital signal, or to shift it by a fraction of the sampling interval [8][9].

V. Filter Technique

5.1 NLM Filtering

The NLM filter (an extension of neighborhood filtering algorithms) is based on the assumption that image content is likely to repeat itself within some neighborhood and in neighboring frames[10][11]. It computes denoised pixel $x(p, q)$ by the weighted sum of the surrounding pixels of $Y(p, q)$ (within frame and in the neighboring frames). This feature provides a way to estimate the pixel value from noisecontaminated images. In a 3-D NLM algorithm, the estimate of a pixel at position (p, q) can be calculated using the equation 5.1,

$$x(i, j) = \frac{\sum_{t=1}^T \sum_{(k,l) \in N(i,j)} w_t(k, l) y_t(k, l)}{\sum_{t=1}^T \sum_{(k,l) \in N(i,j)} w_t(k, l)}, \tag{5.1}$$

where y is the original pixel contaminated with white Gaussian noise, t is the frame index, and the w 's are the filter weights. The weight w is given by the equation 5.2,

$$w(k, l) = \exp \left\{ -\frac{\|p_y(i, j) - p_y(k, l)\|_2^2}{2\sigma^2} \right\} \cdot f(\sqrt{(i - k)^2 + (j - l)^2 + (t - 1)^2}), \tag{5.2}$$

Where the operator p extracts patches centered at $y(i, j)$ and $y(k, l)$, and $\|\cdot\|_2^2$ denotes the Euclidean distance between the two patches. The second term $f(\cdot)$ is a geometric distance function; the weight is inversely proportional to the distance. This denoising algorithm is more robust than other methods because it utilizes information from several frames[12][13].

VI. Simulation And Result

To ascertain the effectiveness of the proposed framelet transform RE algorithm over other wavelet-domain RE techniques, different LR optical images obtained from the Satellite Imaging were tested using MATLAB simulation software and the output of each transforms are compared and the resulting enhanced image are checked for its peak signal to noise ratio and mean square error.

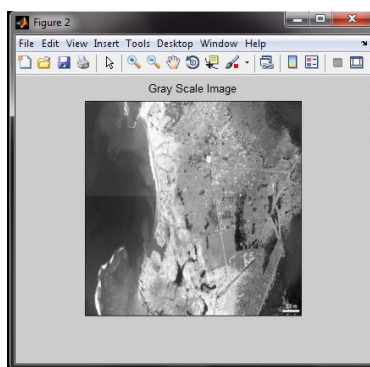

Figure 2: Grey Scale Input Image

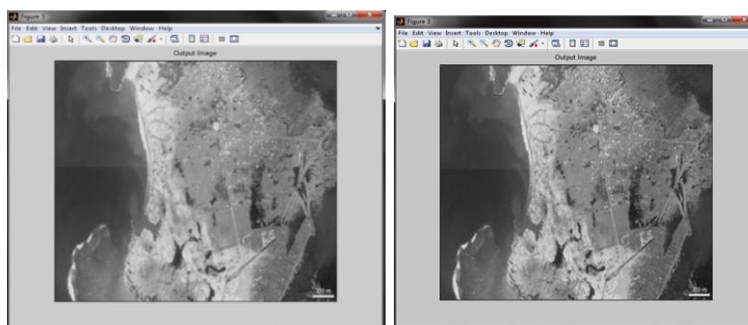

Figure 3: DT-CWT Image

Figure 4: Framelet Transformed Image

Transform	PSNR	MSE
DT-CWT	16.85(db)	0.0258
Framelet transform	17.01(db)	0.0137

Table 1: Results of PSNR and MSE.

Fig. 2 shows the input satellite image of low resolutions used for this study. Fig. 3 shows the simulation output image, using existing Dual Tree- Complex Wavelet (DT-CWT) Transform. Fig. 4 represents the simulation output image produced using the proposed framelet transform technique, which provides better resolution enhancement compared to the DT-CWT transform. The proposed framelet transform provides a better peak signal to noise ratio and less mean square error when compared to the existing transform methods [15] as shown in Table. 1.

VII. Conclusion

The satellite image is dimensioned and converted to grey scale image and fed to the framelet transform by dividing the image into sub-bands and enhanced using the lancsoz interpolation. The output is filtered using Non-local-Mean filter to remove the noise produced during transforming. The output image got from the non-local mean filter and the input image are fed as source images for peak signal noise ratio and mean squared error, the output proves that the processed image has better resolution enhancement in the proposed technique more than the conventional wavelet transform techniques.

REFERENCE

- [1] Y. Piao, I. Shin, and H. W. Park, "Image resolution enhancement using inter-Subband correlation in wavelet domain," 2007
- [2] C. B. Atkins, C. A. Bouman, and J. P. Allebach, "Optimal image scaling using pixel classification," Oct. 7–10, 2001
- [3] H. Demirel and G. Anbarjafari, "Satellite image resolution enhancement using complex wavelet transform," IEEE Jan. 2010.
- [4] H. Demirel and G. Anbarjafari, "Discrete wavelet transform-based satellite image resolution enhancement," IEEE Jun. 2011.
- [5] H. Demirel and G. Anbarjafari, "Image resolution enhancement by using discrete and stationary wavelet decomposition," IEEE May 2011.
- [6] I. W. Selesnick, R. G. Baraniuk, and N. G. Kingsbur, "The dual-tree complex wavelet transform," IEEE Signal Process. Nov. 2005.

- [7] B. Han “*The Structure of balanced of multiwavelets and dual multi framelets*” Math. Comp. 79(2010), 917-951D.
- [8] M. J. Fadili, J. Starck, and F. Murtagh, “*Inpainting and zooming using sparse representations,*” Jan. 2009.
- [9] H. Demirel and G. Anbarjafari, “*Image super resolution based on interpolation of wavelet domain high frequency subbands and the spatial domain input image,*” Jan. 2010.
- [10] H. Zheng, A. Bouzerdoum, and S. L. Phung, “*Wavelet based non-localmeans super-resolution for video sequences,*” IEEE 17th Sep. 26–29, 2010.
- [11] A. Gambardella and M. Migliaccio, “*On the superresolution of microwave scanning radiometer measurements,*” IEEE Geosci. Oct. 2008.
- [12] A. S. Glassner, K. Turkowski, and S. Gabriel Plousky, “*Filters for common resampling tasks,*” 1990
- [13] A. Buades, B. Coll, and J. M. Morel, “*A review of image denoising algorithms, with a new one,*” 2005.
- [14] M. Protter, M. Elad, H. Takeda, and P. Milanfar, “*Generalizing the nonlocal-means to super-resolution reconstruction,*” IEEE Trans. Image Process, Jan. 2009.
- [15] T. Celik, C. Direkoglu, H. Ozkaramanli, H. Demirel, and M. Uyguroglu, “*Region-based super-resolution aided facial feature extraction from lowresolution video sequences,*” in Proc. IEEE Mar. 2005.